

Electric water heater

Read this manual carefully before installation
and use

QHFJI - M5







Contents

1. Safety warnings
2. Technical specifications
3. Special notes
4. Features
5. Dimension specifications
6. Installation method
7. User instructions
8. Function description
9. Detailed function description
10. Cleaning and maintenance
11. Electrical diagram
12. Troubleshooting and troubleshooting
13. Package contents
14. Recycling and reuse

Safety warnings

Symbol	Meaning
	<p>Warning!</p> <p>This symbol indicates a hazard with a medium risk level that, if not avoided, may result in serious injury or death.</p>
	<p>Warning for electrical voltage!</p> <p>This symbol indicates a hazard with a medium risk level that, if not avoided, may result in serious injury or death due to electrical voltage.</p>
	<p>Do not place objects on the device!</p> <p>This symbol on the device indicates that it is forbidden to place objects (such as towels, clothing, etc.) on top of or directly in front of the device. To prevent overheating and fire hazards, the device must not be covered. This sticker must also not be removed from the device.</p>

Please read this manual carefully before using the device.

Always keep the manual in the immediate vicinity of the device or at the place of use.

Read all safety warnings and all instructions carefully.

Failure to follow the warnings and instructions may result in electric shock, fire, and/or serious injury.

Keep all warnings and instructions for future reference.

Failure to follow or correctly follow the instructions in this manual may void the warranty.

 **Attention, warnings!**

Check which series you have purchased and install according to the tips in the installation section.

Please note that if you do not follow these instructions, the warranty on your product will be void.

Remove the protective film (on the front) before use, if present.

Ensure that the operating voltage is between 220–240V, 50Hz and that the power supply strictly complies with IEC standards.

Do not use the device in explosive environments.

Do not use the device in an aggressive atmosphere.

Place the device upright and ensure it is stable when standing or mounted.

Allow the device to dry after cleaning. Do not use the device if it is wet.

Do not use the device with wet or damp hands.

Do not expose the device to direct water spray.

Never insert objects or body parts into the device.

Do not cover or transport the device while in use.

Do not sit, stand, or lean on the device.

This device is not a toy. Keep it out of reach of children, animals, and persons with reduced physical, sensory, or mental capabilities, or lack of experience and knowledge.

Check accessories and connection parts for damage before each use. Never use the device if it has defective components.

Ensure that all electrical cables outside the device are protected from damage (for example caused by animals).

Never use the device if electrical cables or the power connection are damaged.

The electrical connection must comply with the specifications in the technical data section.

Plug the power plug into a properly secured socket. In a damp environment, this socket must be grounded.

Take into account the power consumption of the device, the cable length, and the intended use when selecting extension cords for the power cable. Fully unwind extension cables to avoid electrical overload.

Before carrying out maintenance, care, or repair work on the device, unplug it from the socket. Hold the plug while doing so and only plug it back in once the above has been completed.

Switch off the device and unplug it when it is not in use.

Never use the device if the plug or power cable is damaged. If the power cable is damaged, it must be replaced by the manufacturer, an electrician, or a similarly qualified person to avoid danger.

Defective power cables pose a serious health risk.

When installing the device, observe the minimum distances from walls and other objects, as well as the storage and operating conditions stated in the technical data section.

Never drill into the heater.

Do not use the device in the immediate vicinity of curtains.

Do not place the device in a flammable environment.

Allow the device to cool down completely before transport, maintenance, or similar work.

Do not use the device near bathtubs, shower trays, swimming pools, or other water reservoirs. Check the IP rating of this product in advance, as this determines the correct installation zone.

The product must be installed in such a way that switches and controllers cannot be touched by persons in a bathtub, shower, or swimming pool.

Do not use the device if the socket, cable, or plug is overloaded.



Technical specifications

Model	QHFJI-M5
Connection	230V
Dimensions in cm	See page 11
Weight in kg	30L – 12 kg 50L – 16 kg 80L – 23 kg 100L – 27 kg 120L – 32 kg 150L – 38 kg
Power	1500W / 2000W
IP rating	X4
EAN	
Warranty	2 years
Brand	Quality Heating
Power cable	1,5m
Material	Outer casing is steel, inner tank is enamel

Special Reminders

The following safety guidelines are intended to prevent unforeseen risks or damage caused by unsafe or improper use of the appliance. Please check the packaging and the appliance upon arrival to ensure everything is intact for safe operation. If you notice any damage, please contact your retailer or dealer. Please note that modifications or alterations to the appliance are not permitted for safety reasons. Improper use may lead to hazardous situations and will void the warranty.

Read these operating instructions carefully before using or commissioning the appliance. Keep these instructions in the immediate vicinity of the installation site or the appliance for future reference.

Caution Risk Of Injury!

Before installing this water heater, check and confirm that the power socket is properly grounded. Otherwise, the electric water heater must not be installed or used.

Do not use extension cords. Incorrect installation and use of this electric water heater may result in serious injury and property damage.

Special Cautions

Warning

Non-professionals are not allowed to disassemble the thermal switch to reset. Please contact professionals to maintain. Otherwise our company will not take responsibility if any quality accident happens because of this.

1. The power socket must be properly grounded. The rated current of the socket must be at least 16A. Keep the socket and plug dry to prevent electrical leakage.
2. The wall on which the electric water heater is installed must be able to support at least twice the weight of the heater when fully filled with water, without deformation or cracks. Otherwise, appropriate reinforcement measures must be taken.

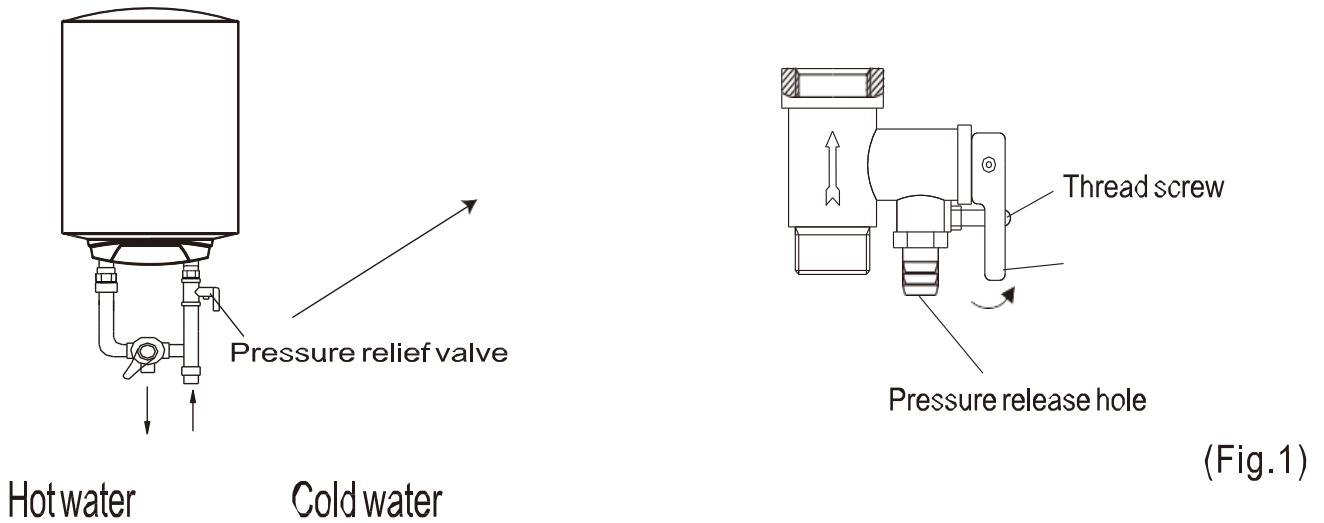

- If the appliance will not be used for an extended period, the water inside the tank must be completely drained.
- The safety valve must be installed at the water inlet (see Fig. 1). Ensure that it is not exposed to moisture. Water may discharge from the pressure relief valve during operation. The valve must be checked and cleaned regularly to prevent blockage.
- When using the heater for the first time, or after maintenance, do not switch it on until it is completely filled with water. During filling, open the hot water tap to release air from the system. Close the tap once the heater is fully filled.
- This appliance is not intended for use by persons (including children) with reduced physical, sensory, or mental capabilities, or lack of experience and knowledge, unless they are supervised or instructed in the safe use of the appliance by a person responsible for their safety. Children and vulnerable persons must always be supervised when using the appliance.

- During heating, small amounts of water may drip from the pressure relief opening of the safety valve. This is normal. If excessive water leakage occurs, please contact customer service for repair. The pressure relief opening must never be blocked, as this may cause damage or accidents.
- The water temperature inside the heater can reach up to 75°C. Avoid direct contact with hot water, especially during initial use. Set the water temperature to a suitable level to prevent scalding.
- If the power supply cord is damaged, it must be replaced with a special cord supplied by the manufacturer and installed by qualified service personnel.
- If any parts or components of the electric water heater are damaged, please contact customer service for repair.
- Children must be supervised to ensure they do not play with the appliance.
- The drain pipes must be installed in a frost-free environment. Protect inlet and outlet pipes from freezing.
- This electric water heater complies with the requirements of EN 60335-1 and EN 60335-2-21.
- Always disconnect the power supply before performing maintenance to avoid risks such as electric shock.
- During normal operation, the inlet valve must always remain open.
- To drain the water from the tank, use the pressure relief valve. Unscrew the valve and lift the drain handle to release the water.

Features

Purpose:

The electric water heater is suitable for providing hot water for showers and washing in households, commercial environments, institutions, and service facilities.

Characteristics:

1. The heater features an adjustable temperature control, allowing the temperature to be set between 30°C and 75°C.
2. A heating indicator light shows the current operating status.
3. Automatic temperature control and insulation ensure a continuous supply of hot water.
4. The unit includes multiple safety protections, such as overheat protection, water overpressure protection (automatic pressure relief when tank pressure is too high), and anti-backflow protection.
5. The product is equipped with an enamel-coated heating element and an enamel-coated inner tank, both resistant to corrosion and scaling. It also includes a magnesium anode rod to protect the inner tank and extend its service life.
6. The insulation layer is made of thickened polyurethane foam, providing effective thermal insulation and energy efficiency.
7. A water mixing valve is included to regulate the outlet water temperature easily and precisely.
8. The unit supports multi-point water supply, allowing it to provide hot water to multiple outlets simultaneously.

Rated Capacity (L)	30	50	80	100	120	150
Rated Power	1500W			2000W		
Rated Voltage	220 ~ 240VAC/50-60HZ					
Rated Pressure	0,8MPa					
Maximum Set Temperature	80					

Dimension specifications

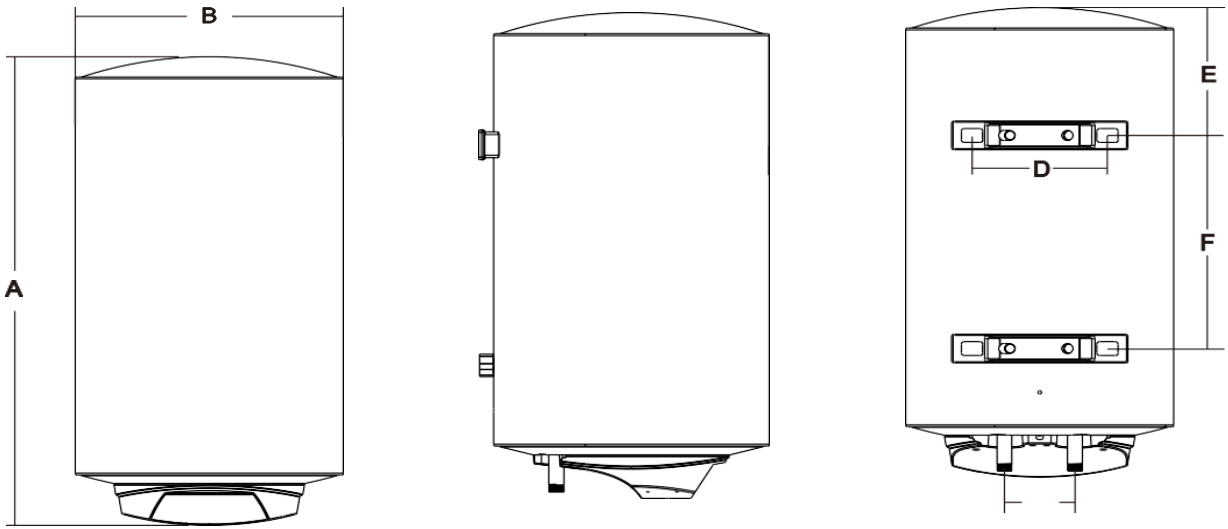

Capacity / Dimension(mm)	30L	50L	80L	100L	120L	150L
A	635	760	840	1000	1150	1380
B	340	380	450	450	450	450
C	100	100	100	100	100	100
D	200	200	200	200	200	200
E	185	205	205	230	210	210
F	240	341	331	447	640	865

Installation method

The electric water heater must be installed by qualified professionals in accordance with national regulations and standards for the installation of electric water heaters.

1. Installation Preparation

(1) Qualified installation personnel must prepare the necessary installation tools and properly calibrated measuring instruments.

(2) Check whether the electric water heater is in good condition and ensure that all supplied accessories and documentation are complete.

(3) Carefully read the user manual to understand the functions, operating methods, installation requirements, and installation procedures of the electric water heater.

(4) Verify that the power supply meets the requirements of 220–240V AC, 50–60Hz. The electrical connection must use a dedicated circuit with a capacity of at least 1.5 times the maximum current of the water heater.

The fixed socket must be installed in a safe location, protected from water exposure and risk of electric shock. The socket must be inspected using appropriate measuring instruments (such as a phase tester and grounding resistance meter) to ensure correct wiring and reliable grounding.

Check whether the capacity of the electricity meter, wiring, and socket meet the requirements of the water heater.

Check the water pressure of the inlet using a pressure gauge. A safety valve must be installed on the inlet pipe. The rated pressure of the water heater is 0.8 MPa. If the inlet pressure exceeds 0.8 MPa, the safety valve will release pressure automatically to protect the appliance.

(5) Assist the user in selecting a suitable installation location. Avoid areas where flammable gases may leak or where corrosive gases are present.

Avoid locations exposed to strong electromagnetic fields. Avoid direct sunlight, rain, and wind. Avoid areas prone to vibration.

Minimize the distance between the water heater and the water outlet to reduce heat loss in the pipes. Ensure that a floor drain is available at the installation site.

Ensure sufficient drainage capacity near the lower part of the installation area to prevent drainage failure.

To facilitate future repairs, maintenance, and relocation, sufficient space must be reserved around the installation position of the electric water heater. The load-bearing capacity of the mounting surface must be at least four times the total weight of the water heater when fully filled with water. Otherwise, a suitable support bracket must be installed underneath the unit to ensure safety.

Notes:

1. Before connecting the water pipes, thoroughly clean the supply pipes to prevent metallic or foreign particles from entering the water heater.
2. Install the water heater according to the diagrams shown in Figures 1 and 2. The unit must be installed with the safety group, including a non-return valve (supplied with the water heater).
3. Do not install any hydraulic accessories between the safety group and the cold water inlet pipe (such as stop valves or additional non-return valves).
4. Proper disposal of this appliance helps prevent potential negative consequences for the environment and human health. It also enables the recycling of materials and contributes to energy and resource savings. For more information, contact your local authority or the retailer where the product was purchased.
5. During heating, the water expands and may cause dripping (approximately 3% of the tank capacity per heating cycle). This is normal.
To drain the water heater, operate the safety group lever as shown in Figure 3. It is recommended to operate this lever periodically to prevent it from sticking and to ensure proper operation.
6. If the supply water pressure exceeds 0.5 MPa, a pressure reducer must be installed at the household inlet and set to 0.3 MPa or 0.4 MPa.
7. If plastic pipes are used during installation, consider the pressure and temperature conditions. Pipes connected to the water heater must be resistant to at least 0.8 MPa and temperatures above 100°C. Use sealing tape on all connections to ensure leak-proof joints.

2. Installation Procedure

- 1.The supplied accessories must be used for the installation of the electric water heater. Installation personnel must not replace, omit, or modify these components.
- 2.During installation, care must be taken not to damage the structural integrity of the building.
- 3.The pipes and fittings used for the installation must comply with national standards and follow the manufacturer's instructions in this manual.

No non-return valve or shut-off valve may be installed between the water heater and the safety valve, as this may interfere with normal operation.

If an additional non-return valve is installed between the inlet pipe and the safety valve connected to the main water supply, an expansion tank must be installed after the non-return valve to prevent overpressure and possible damage to the tank.

- 4.Determine a suitable installation location for the electric water heater. Avoid drilling into reinforced or embedded pipelines in the wall.

Use an impact drill to create two holes in a solid wall with a diameter of 13 mm and a depth of 85 mm (for 30–100L models). The holes must be aligned horizontally, with spacing as specified in the table above.

Ensure that at least 600 mm of space is available on the right side of the water heater for maintenance.

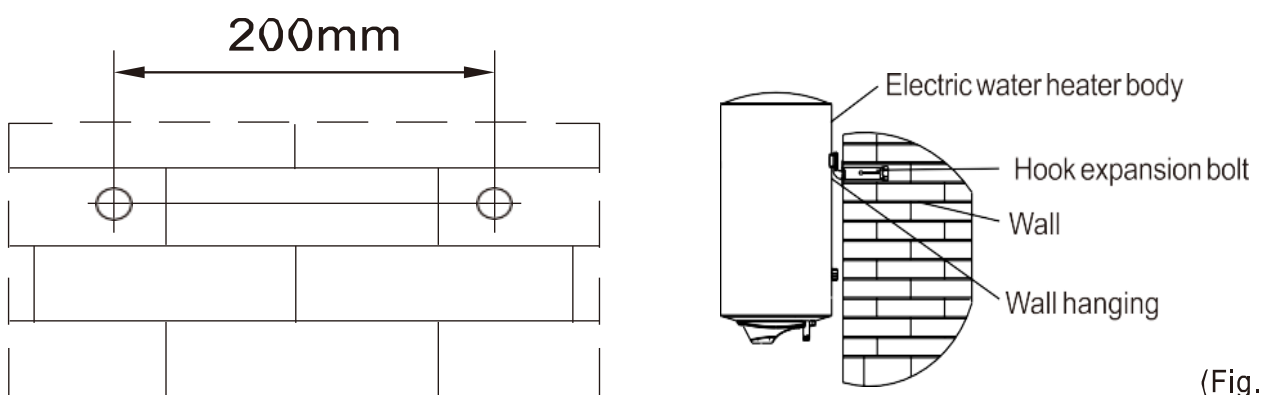

(Fig.2)

Note: floor mounted installation is not allowed.

5. Insert the hook expansion bolts into the drilled holes, tighten them securely, and ensure

6. the hooks are facing upward.

Lift the electric water heater and align the mounting brackets with the hooks of the expansion bolts. Check that the bolts are firmly secured to ensure the water heater is safely and securely installed.

7. Connect the safety valve, drainage hose, water mixing valve, water inlet pipe, and shower to the electric water heater. Ensure that sealing rings are properly installed at all connection points to prevent leakage.

Notes:

1. The safety valve (factory setting: 0.8 MPa), supplied with the unit, must be installed at the cold water inlet. Apply PTFE sealing tape to all threaded connections to ensure a watertight seal.

Ensure that the arrow on the safety valve corresponds with the direction of water flow into the electric water heater (see Fig. 3). The sealing gasket must be installed at the cold water inlet of the safety valve. The valve must be installed in a frost-free environment.

The safety valve prevents the tank pressure from exceeding the rated pressure by 0.1 MPa. If the internal pressure becomes too high, the valve will automatically open and discharge water through the pressure relief outlet to release excess pressure.

The safety valve prevents the tank pressure from exceeding the rated pressure by 0.1 MPa. If the internal pressure becomes too high, the valve will automatically open and discharge water through the pressure relief outlet to release excess pressure.

2. The connection size of each pipe is G1/2". The pressure relief valve must be connected to the water inlet of the heater.

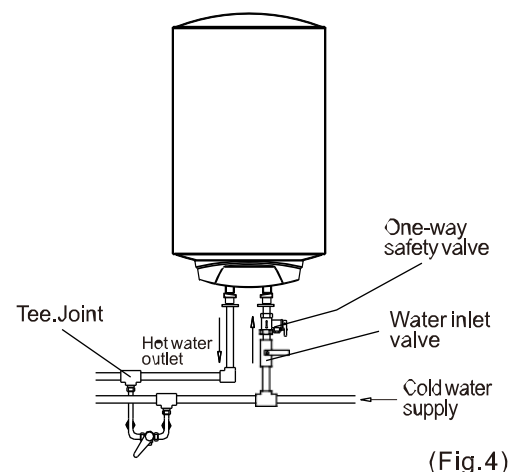
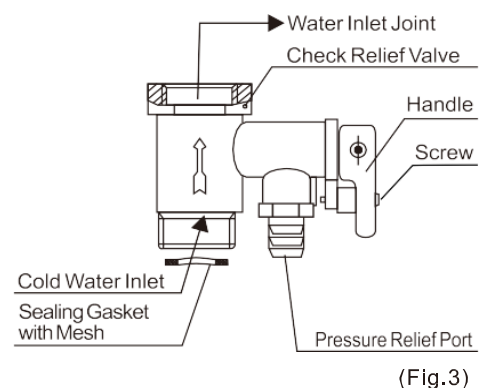

To prevent leakage when connecting the pipelines, the rubber sealing gaskets supplied with the heater must be installed at the threaded connections.

3. The water pipes connected to the electric water heater must be able to withstand a pressure of at least 0.8 MPa and a temperature above 100°C. All threaded joints must be sealed with PTFE tape to ensure leak-proof connections.

4. The installation must allow for smooth water drainage.

5. During normal use, the handle of the safety valve (see Fig. 3) should be operated regularly to remove limescale deposits.

To do this, lift the discharge handle upwards to the horizontal position. If the handle is secured with screws, remove them first using a screwdriver.

Check whether the safety valve is functioning properly (water discharge should occur). If it is blocked, contact the service department.

6. For multi-point water supply, connect the water pipes according to the method shown in Fig. 4.

7. After verifying that the electricity meter, wiring, switches, sockets, and fuses meet the required specifications, connect a dedicated power socket at a suitable location to supply power to the water heater.

The installation height of the power socket must be at least 1.8 meters above the ground.

Notes:

1. Do not install the socket in a location where it may come into contact with water.

2. The socket must have a reliable grounding connection.

3. Keep the socket dry to prevent electrical leakage. Electrical installation must be carried out by qualified professionals.

3. Inspection and Commissioning

1. Ensure that all pipe connections are correctly installed and that there are no leaks.

2. Verify that the electrical installation is safe and correct, that the unit is properly grounded, and that the plug and socket fit securely.

3. Ensure that all mechanical connections are firm and secure.

4. Check for possible electrical leakage using a test pen or multimeter to ensure safe operation of the water heater.

5. Operate the electric water heater according to the instructions in this manual. All performance parameters must comply with the specifications stated in this manual.

User instructions

1. When using the water heater for the first time, or after draining the tank, the tank must be completely filled with water before switching on the unit.

To fill the tank, open the water inlet valve. Lift the handle of the mixing valve and turn it clockwise to the high-temperature position to allow water to flow into the inner tank.

When water flows steadily from the hot water outlet, the tank is fully filled. Then turn the handle of the mixing valve counterclockwise to the low-temperature position and push it to the closed position (see Fig. 5).

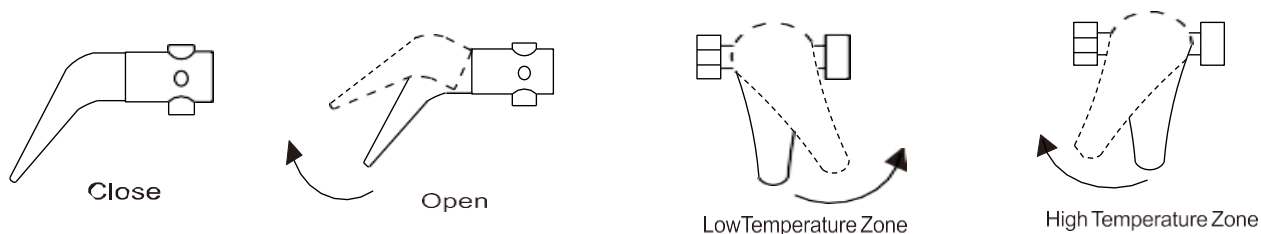

(Fig.5)

2. Plug the power cord into the electrical outlet to switch on the water heater. The display will light up.

If the power cord is damaged, it must be replaced by the manufacturer, its service department, or a similarly qualified professional to avoid danger.

3. Instructions for the Leakage Protection Plug (see Fig. 6)

3.1 The leakage protection plug must not be used as a switch for the appliance. During normal use, the plug should be tested regularly as described below.

3.2 Press the test button. The indicator light should turn off and the reset button should pop up.

Then press the reset button. If the indicator light turns on again, the leakage protection plug is functioning correctly.

If the indicator light does not turn on, stop using the appliance immediately and contact a qualified service technician.

In case of a fault, stop using the water heater immediately and contact the after-sales service department for assistance.

Users should check for electrical leakage regularly, at least once a month, following the procedure described above.

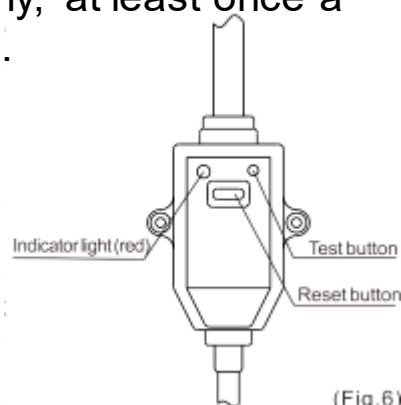

(Fig.6)

3.3 Disconnecting the Power Supply

If it is necessary to temporarily disconnect the power supply, press the test button on the leakage protection plug to switch off the power. Do not switch off the power directly at the socket, as the leakage protection plug will not provide protection in that case.

4. Operation Description

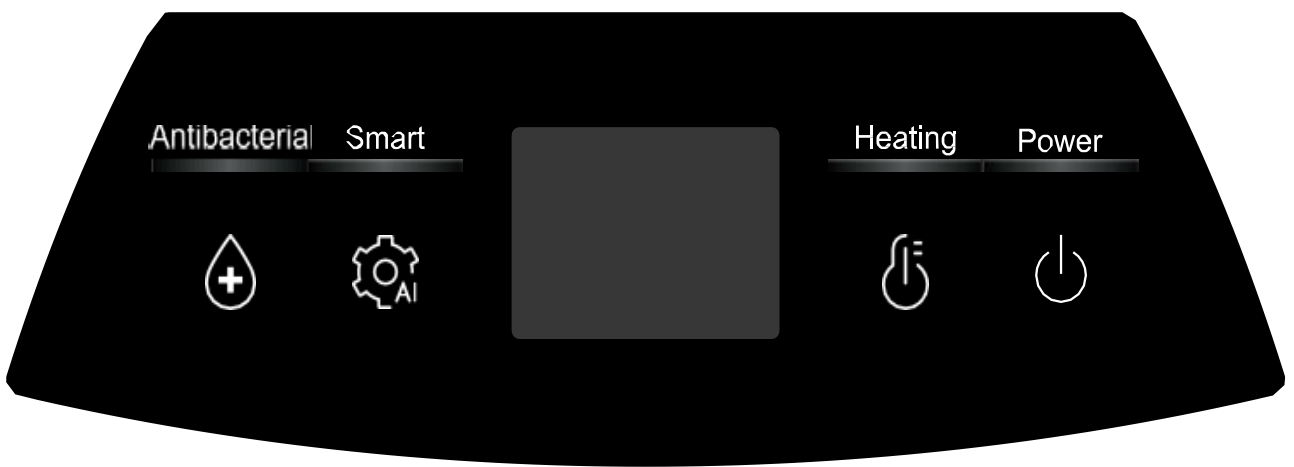

Operating Method

1. Power Button

Connect the power supply. The display (including indicator lights) will illuminate for 2 seconds and then enter standby mode or return to the previous operating state before power-off.

In standby mode, the display shows the current temperature.

Press the power button once to switch on the device and enter working mode. The display will alternate between the actual temperature (for 10 seconds) and the set temperature (for 3 seconds).

2. Temperature Adjustment Button

When the device is switched on, press the temperature adjustment button to enter temperature setting mode. The set temperature will flash on the display.

Each press of the button increases the temperature by 1°C within a range of 30°C to 75°C.

Press and hold the button to quickly cycle through the temperature settings (30–31–32–...–75°C).

Holding down the button will adjust the temperature setting at a rate of 5 increments per second.

If no changes are made within 5 seconds, the system will automatically confirm the current setting and return to the normal operating state. The temperature display will stop flashing.

3. Smart Mode Button

When the device is powered on, press and hold the Smart Mode button for 3 seconds to activate Smart Mode.

In Smart Mode, the system analyzes and memorizes the user's water usage patterns over time. If Smart Mode has been active for less than one week, the system will first complete a full learning cycle. During this period, the Smart Mode indicator will light up orange. Once learning is complete, the indicator will turn blue.

After learning, the water heater will automatically start heating approximately one hour before the expected usage times.

During periods of no water usage, the heater will also operate as needed to maintain available hot water.

Note: If a power interruption occurs or Smart Mode is disabled, all stored usage data will be cleared.

To deactivate Smart Mode, press and hold the Smart Mode button for 3 seconds. The indicator light will turn off.

4. High-Temperature Sterilization Button

When the device is powered on, press and hold the sterilization button for 3 seconds to activate or deactivate the high-temperature antibacterial mode.

When activated, the indicator light will turn on and the temperature will be set to 80°C.

Once the water reaches 80°C, the system will maintain this temperature. When the temperature drops by 5°C, the heater will reheat to 80°C.

After maintaining this temperature for 30 minutes, the system will exit the antibacterial mode and return to the previous operating mode.

Detailed function description

1. Heating Function

When switched on, the water heater starts heating immediately. Once the set temperature is reached, the heater stops heating and enters insulation mode.

If the water temperature drops by 8°C below the set temperature, the heater will automatically restart and repeat the heating cycle.

The heating indicator light remains on during the heating process.

2. Thermal Insulation Function

When the unit enters insulation mode, the heating indicator light turns off.

3. Automatic Screen Function

3.1 In standby mode, the display brightness is reduced to half.

3.2 When the device is powered on and no buttons are pressed for 3 consecutive minutes (excluding heating and anti-freeze modes), the device enters screen saver mode.

In this mode, the display dims and only the current temperature is shown. The indicator light for the active mode remains on.

3.3 Screen saver mode will not activate during heating or anti-freeze operation.

3.4 Pressing any button will wake up the display. The screen will return to the previous interface, and normal operation can resume.

Pressing the power button in standby mode will switch the device on directly.

4. Memory Function

The device includes a memory function that stores settings such as power status and temperature. After a power interruption, the unit will automatically return to the previous operating state.

5. Memory Reset Function

Press and hold both the power button and the temperature button simultaneously for 3 seconds.

The display will fully illuminate, and the device will reset to factory settings with a confirmation beep. After resetting, the unit will enter standby mode. Upon switching on, the default temperature will be set to 75°C in instant heating mode.

6. Anti-Freeze Protection Function

When the system detects that the water temperature in the inner tank is $\leq 6^{\circ}\text{C}$ while the device is in standby mode, it will automatically start heating.

Heating will stop once the water temperature reaches $\geq 10^{\circ}\text{C}$.

During this process, no indicators will be shown on the display or indicator lights, as the system operates in a concealed heating mode.

7. Buzzer Function

The appliance is equipped with a buzzer for audible feedback.

Each valid button operation will produce a single beep.

In the event of a fault, the buzzer will sound 10 times.

8. Safety Self-Check Function

The appliance continuously performs automatic safety checks in both standby and operating modes.

These include protection against dry heating, sensor faults, and overheating.

9. Alarm and Fault Indication

In case of faults such as dry heating, sensor errors (sensor 1 or 2), or overheating, the display will show error codes E2, E3/E5, or E4 respectively.

During a fault condition, the display and indicator lights may be inactive, all relays will be disconnected, and all buttons will be disabled.

The system will only return to standby mode after the fault has been resolved and the unit has been restarted.

Cleaning and maintenance



Warning

Always disconnect the power supply before performing maintenance to avoid hazards such as electric shock.

- Regularly check the power plug and socket to ensure a secure electrical connection and proper grounding. The plug and socket must not overheat.
- If the heater will not be used for an extended period, especially in areas where temperatures may drop below 0°C, the water must be drained from the tank to prevent damage caused by freezing. Refer to the instructions in this manual for proper draining procedures.
- To ensure long-term reliable operation, it is recommended to periodically clean the inner tank and remove any deposits from the heating element. The cleaning frequency depends on the hardness of the water in your area. Maintenance should be carried out by qualified service personnel. You can contact your supplier for the address of the nearest service center.

Electrical diagram

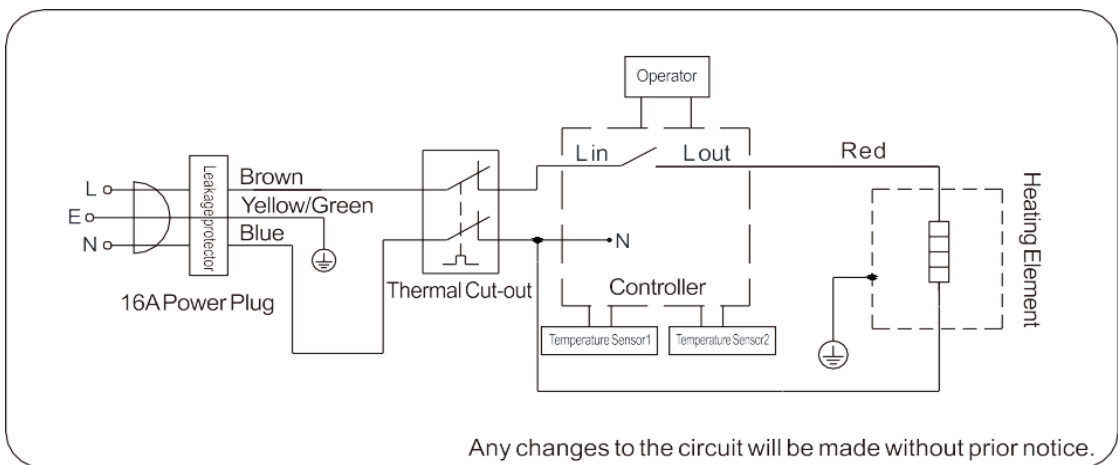

Troubleshooting and troubleshooting

Faults	Analysis of Causes	Troubleshooting
No water from hot water outlet	The water supply system is cut off or the water pressure is too low	Check the water supply system
	The inlet valve is not opened or the water mixing valve fails	Open the water inlet valve or replace the water mixing valve
The outlet water is cold(Heating indicator is off)	Power failure or power switch in off position	Check the power supply line
	Internal circuit failure	Contact the official technical support department
	Thermostat failure	Contact the official technical support department
The outlet water is cold(Heating indicator light is on)	Heating element failure	Contact the official technical support department
	Heating time is too short	Continue heating
	Water mixing valve failure	Replace the water mixing valve
	Internal circuit failure	Contact the official technical support department
Error code“E2”	The water heater is not filled with water and directly electrified, resulting in dry burning	Cut off the power supply, fill the water heater with water and then energize it
Error code“E3/E5”	Whether the sensor is damaged (E3 is sensor 1, E5 is sensor 2.)	Contact the official technical support department
Error code“E4”	The heating water temperature is out of control and exceeds 90°C	Contact the official technical support department

Note:





If your electric water heater operates abnormally, please follow the instructions in the “Fault Description and Troubleshooting” section.

If you encounter any electrical issues, contact the official technical support department designated by the manufacturer.

Packing list

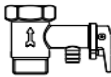
After unpacking the product, please check the accessories and documentation against the packing list below. If any items are missing or damaged, please contact your dealer or the company's after-sales service department in a timely manner. Please retain this instruction manual for future reference, operation, and maintenance.

The packing list is as follows:

Name	Quantity	Dimension Sketch	Notes
Electric Water Heater	1 Unit		
Safety Valve	1 Piece		Mount to water inlet connection of water heater
Accessory Kit	1 Piece		Two screws+two plastic parts+one net washer
Operation Manual	1 Piece		Keep properly
Energy Efficiency Label	1 Piece		

Recycling and Reuse



Dispose of the packaging in an environmentally responsible manner. This appliance is labeled in accordance with European Directive 2012/19/EU on Waste Electrical and Electronic Equipment (WEEE).

This directive sets out the framework for the return and recycling of used electrical and electronic appliances across the European Union.

Package Information

The packaging materials of this product are made from recyclable materials in accordance with national environmental regulations.

Do not dispose of the packaging materials together with household or other waste. Please take them to designated collection points for packaging materials as specified by local authorities.