

# User Manual

## EPS BOX-SP

Please read this manual carefully before use to avoid improper operation.

# Contents

1 Introduction .....	1
1.1 Basic Features .....	1
1.2 Dimensions .....	2
1.3 Ferrules of EPS BOX-SP .....	2
1.4 Wiring Diagram .....	3
1.5 Symbols Used .....	6
2 Installation .....	8
2.1 Check for Physical Damage .....	8
2.2 Packing List .....	8
2.3 Mounting .....	9
3 Electrical Connection .....	13
3.1 Wiring Connection .....	13
3.1.1 INVERTER GRID & INVERTER EPS Wiring Instructions .....	14
3.1.2 UTILITY SUPPLY & LOAD Wiring Instructions .....	15
3.1.3 RS485 Wiring Instructions .....	17
3.1.4 INVERTER 2 Wiring Instructions .....	20
3.1.5 Schematic Diagram After Completing Wiring .....	21
3.2 Earth Connection .....	24
4 Check After Installation .....	25
4.1 Check After Installation .....	25
4.2 Maintenance .....	25
5 Technical Data .....	26

# 1 Introduction

## 1.1 Basic Features

EPS BOX-SP, an auxiliary product of KH / HI-G2 / EVO series, is suitable for the residential power system and integrates Smart Meter, Breaker, ATS and other devices internally.

The EPS BOX-SP can support continuous loads up to 100A, enabling whole-house backup power without interruption.

The EPS BOX-SP features grid-tie/off-grid automatic switching, detects power failures instantly, and delivers rapid backup power activation. The power supply status of the load can be switched automatically or manually and the automatic switching time is less than 3s. EPS BOX-SP will automatically switch to the reserve power supply side (EPS terminal of the inverter) to supply power to the load when the power grid fails. And it will switch to the power grid side to supply power to the load when the power grid is restored.



## 1.2 Dimensions (mm)

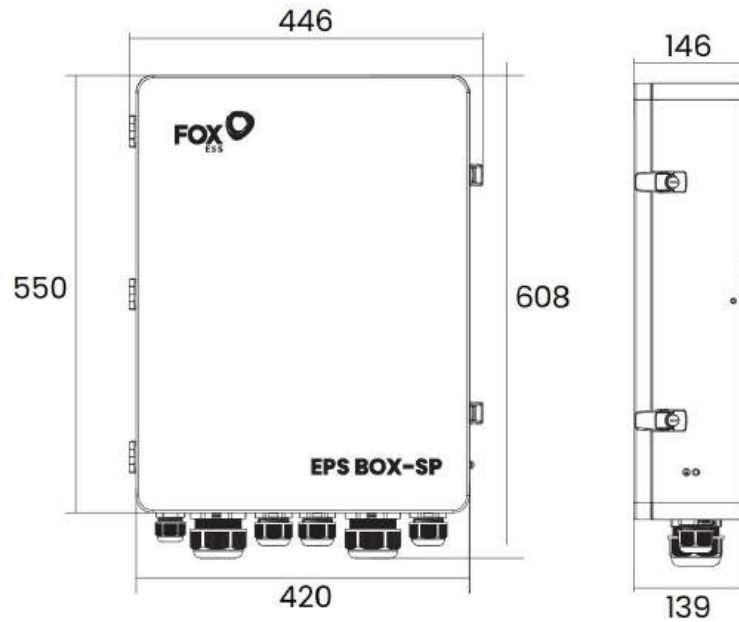

## 1.3 Ferrules of EPS BOX-SP

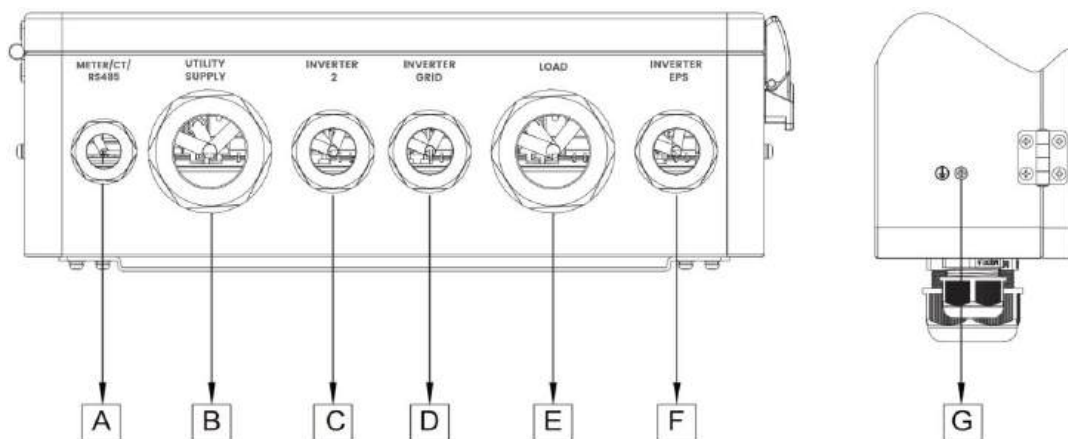

Item	Description	Item	Description
A	METER/CT/RS485	E	LOAD
B	UTILITY SUPPLY	F	INVERTER EPS
C	INVERTER 2	G	GROUND
D	INVERTER GRID		

### NOTE

Only authorized personnel are permitted to set the connection.

## 1.4 Wiring Diagram

The wiring diagram of EPS BOX-SP is shown below.

- Wiring diagram of EPS BOX-SP with KH series

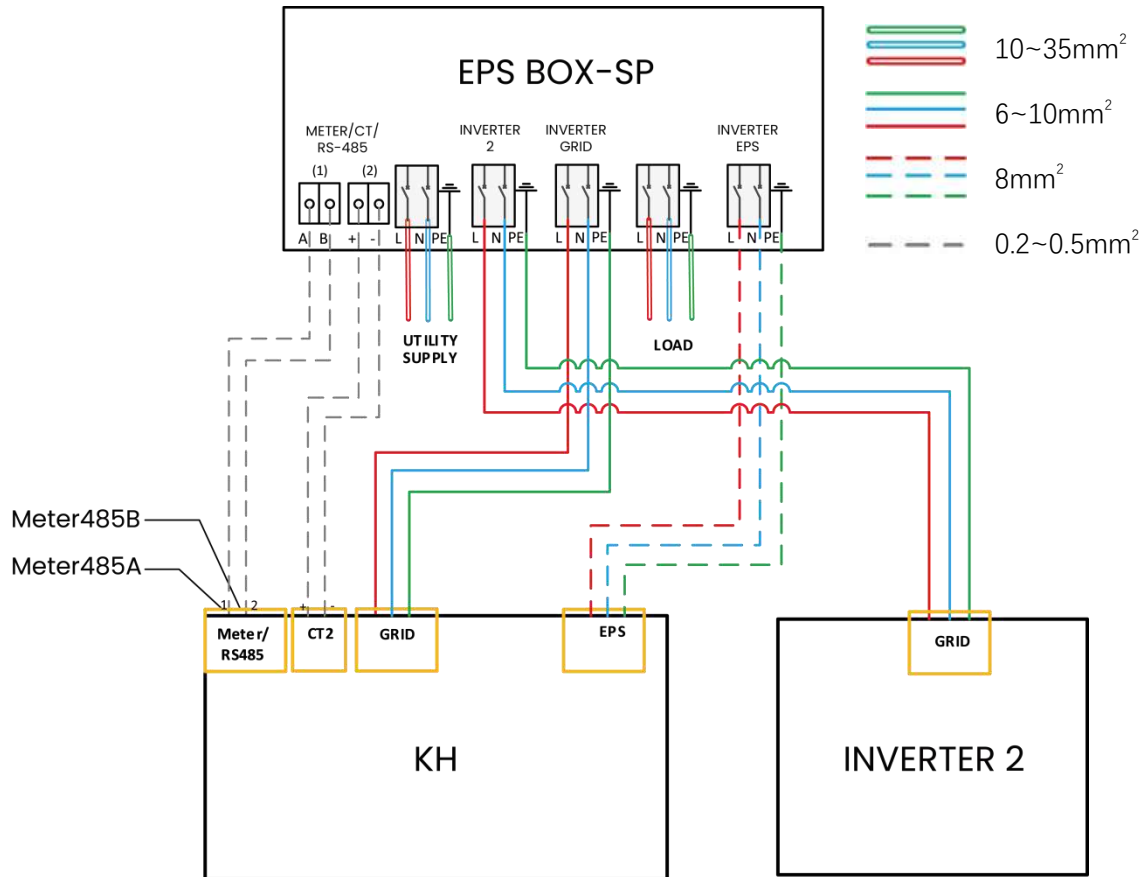

The pin definitions of Meter / RS485 interface for KH series:

PIN	1	2
Definition	Meter485A	Meter485B

- Wiring diagram of EPS BOX-SP with HI-G2 series

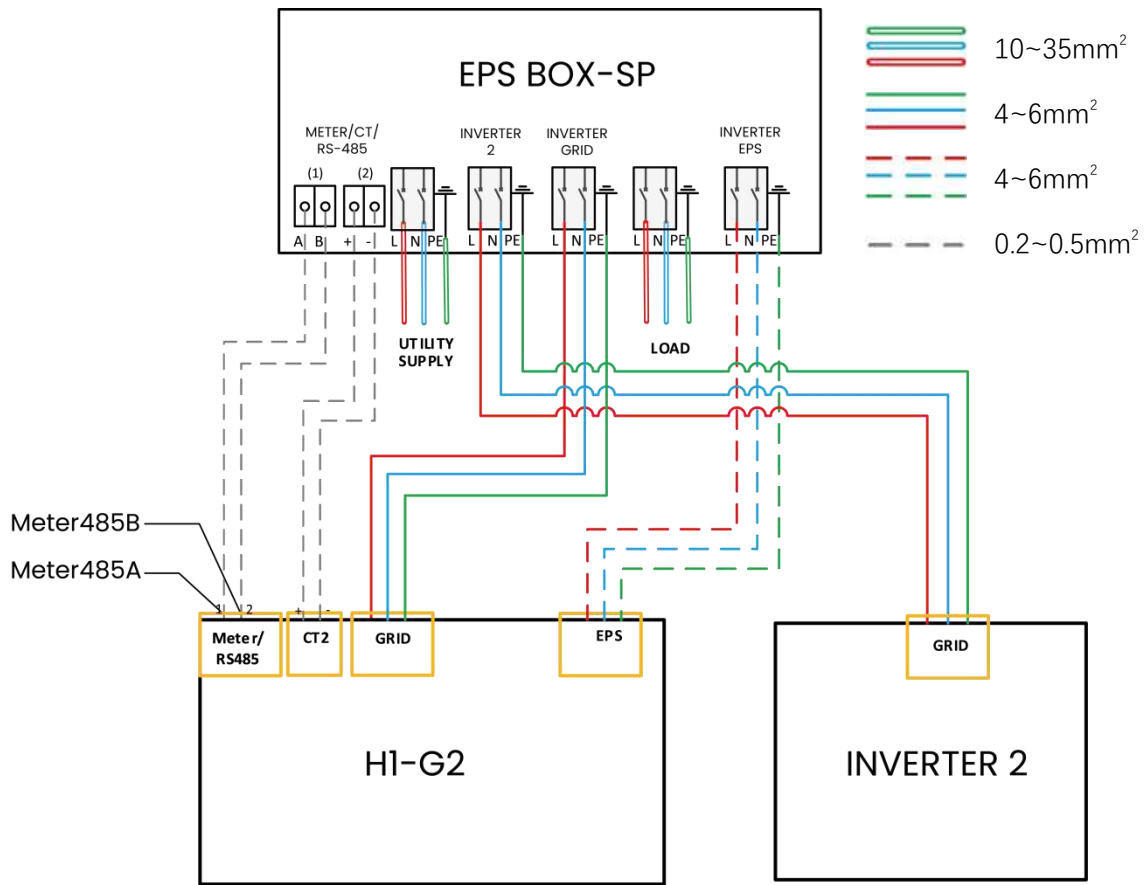

The pin definitions of Meter / RS485 interface for HI-G2 series:

PIN	1	2
Definition	Meter485A	Meter485B

- Wiring diagram of EPS BOX-SP with EVO series

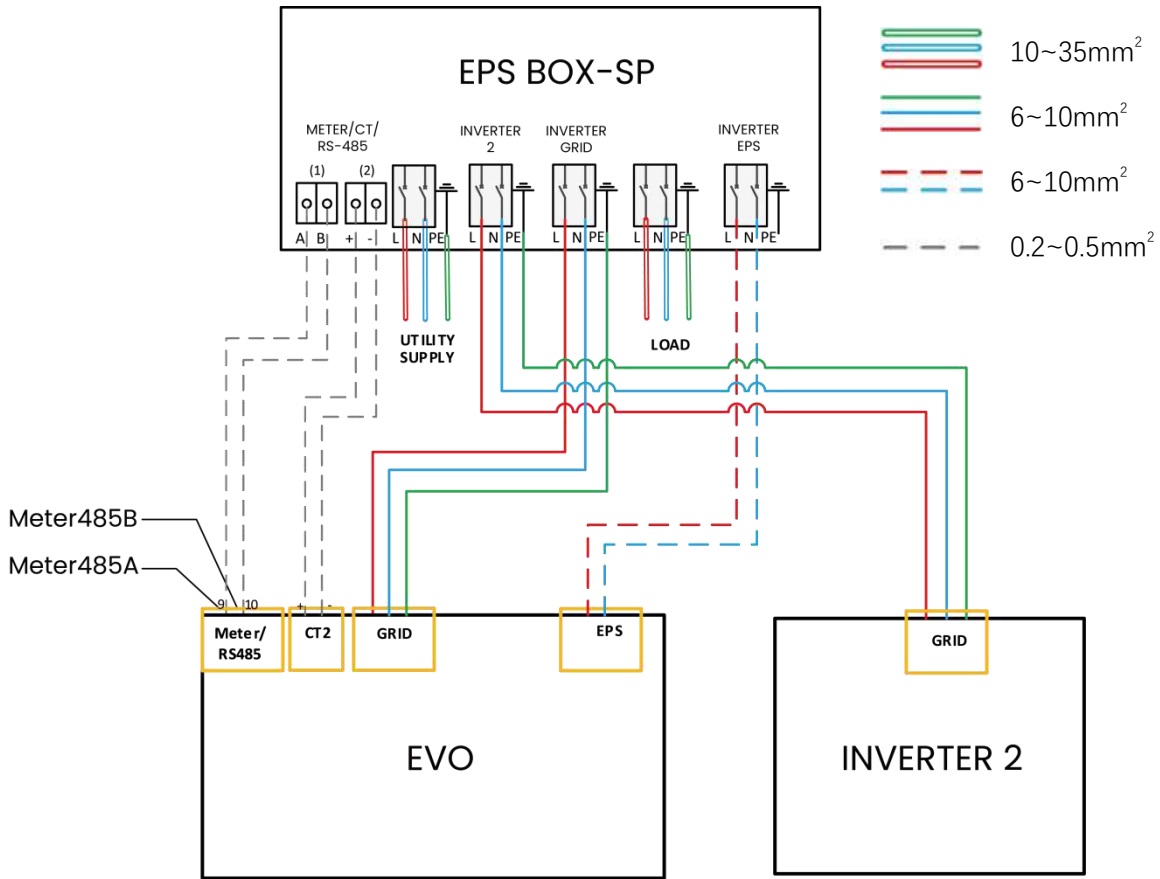

The pin definitions of Meter / RS485 interface for EVO series:

PIN	9	10
Definition	Meter485A	Meter485B

The wire gauge shown in the above diagram is for reference only. Users can select an appropriate wire gauge based on the inverter power and load power. The wire gauge reference specifications are as follows:

Interface	INVERTER 2/INVERTER GRID/INVERTER EPS	UTILITY SUPPLY/LOAD
Cable	14-22mm	16-37mm

**Table 24 – Sizes of conductors**



Rated current of equipment  A	Minimum conductor sizes			
	Nominal cross-sectional area		AWG or kcmil [cross-sectional area in mm <sup>2</sup> ]	
	mm <sup>2</sup>		see note 2	
Up to and including 6		0,75 <sup>1)</sup>	18	[0,8]
Over 6 up to and including 10	(0,75) <sup>2)</sup>	1,00	16	[1,3]
Over 10 up to and including 13	(1,0) <sup>3)</sup>	1,25	16	[1,3]
Over 13 up to and including 16	(1,0) <sup>3)</sup>	1,5	14	[2]
Over 16 up to and including 25		2,5	12	[3]
Over 25 up to and including 32		4,0	10	[5]
Over 32 up to and including 40		6,0	8	[8]
Over 40 up to and including 63		10	6	[13]
Over 63 up to and including 80		16	4	[21]
Over 80 up to and including 100		25	2	[33]
Over 100 up to and including 125		35	1	[42]
Over 125 up to and including 160		50	0	[53]
Over 160 up to and including 190		70	000	[85]
Over 190 up to and including 230		95	0000	[107]
Over 230 up to and including 260		120	250 kcmil	[126]
Over 260 up to and including 300		150	300 kcmil	[152]
Over 300 up to and including 340		185	400 kcmil	[202]
Over 340 up to and including 400		240	500 kcmil	[253]
Over 400 up to and including 460		300	600 kcmil	[304]
1) For rated current up to 3 A, a nominal cross-sectional area of 0,5 mm <sup>2</sup> is permitted in some countries provided the length of cord does not exceed 2 m.				
2) The value in parentheses applies to detachable power supply cords fitted with the connectors rated 10 A in accordance with IEC 60320 (types C13, C15, C15A, and C17) provided that the length of the cord does not exceed 2 m.				
3) The value in parentheses applies to detachable power supply cords fitted with the connectors rated 16 A in accordance with IEC 60320 (types C19, C21, and C23) provided that the length of the cord does not exceed 2 m.				
NOTE 1 IEC 60320 specifies acceptable combinations of appliance couplers and flexible cords, including those covered by items 1), 2), and 3). However, a number of countries have indicated that they do not accept all of the values listed in table 3B, particularly those covered by conditions 1), 2), and 3).				
NOTE 2 AWG and kcmil sizes are provided for information only. The associated cross-sectional areas, in square brackets, have been rounded to show significant figures only. AWG refers to the American Wire Gage and the term "cmil" refers to circular mils where one circular mil is equal to the area of a circle having a diameter of one mil (one thousandth of an inch). These terms are commonly used to designate wire sizes in North America.				

**⚠ CAUTION**

1. When the inverter is in off-grid state, the load power shall not exceed the maximum output power of the off grid inverter. We will not be responsible if the machine is unable to operate normally due to high load;
2. When the grid voltage is normal, the maximum current of both the UTILITY SUPPLY port and the Load port should not exceed 100A.

## 1.5 Symbols Used

The following types of safety instructions and general information appear in this document as described below:

 <b>DANGER</b>
"Danger" indicates a hazardous situation which, if not avoided, will result in death or serious injury.
 <b>WARNING</b>
"Warning" indicates a hazardous situation which, if not avoided, could result in death or serious injury.
 <b>CAUTION</b>
"Caution" indicates a hazardous situation which, if not avoided, could result in minor or moderate injury.
<b>NOTE</b>
"Note" provides important tips and guidance.

## 2 Installation

### 2.1 Check for Physical Damage

Ensure that the EPS BOX-SP is intact during transportation. If there is any visible damage, such as cracks, please contact your dealer immediately.

### 2.2 Packing List

Please check the accessories after you open the package and remove the product. There should have the parts as shown below:

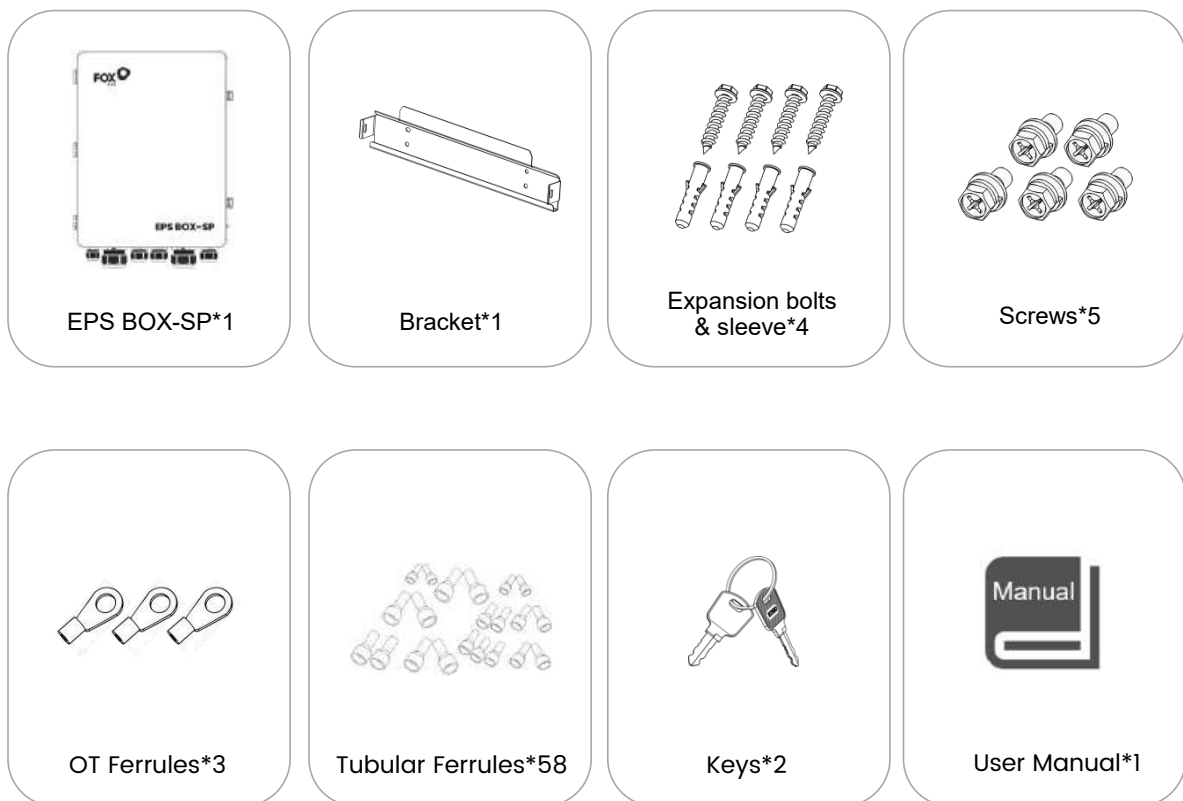

\*Please see the table below for the models of tubular ferrules and the corresponding quantity.

Terminal model	RNY5.5-6	RNY5.5-6-90D	E7510	TF7510	E6012	E10-12	E16-12	E25-16	E35-16
Wire diameter (mm <sup>2</sup> )	4~6	4~6	0.5~0.75	2×0.75	5~6	8~10	13~16	21~25	32~35
Quantity	1	2	6	2	11	9	15	6	6

## 2.3 Mounting

### Installation Precaution

Ensure that the installation site meets the following conditions:

- Not in direct sunlight.
- Not in areas where highly flammable materials are stored.
- Not in potential explosive areas.
- Not in the cool air directly.
- Not near the television antenna or antenna cable.
- Not higher than altitude of about 2000m above sea level.
- Not in environment of precipitation or humidity (> 95%).
- Under good ventilation condition.
- The ambient temperature in the range of -25°C to +60°C.
- The slope of the wall should be within +5\*.

The wall hanging the EPS BOX-SP should meet conditions below:

A.Solid brick/concrete, or strength equivalent mounting surface;

B.EPS BOX-SP must be supported or strengthened if the wall is not firm enough (such as wooden wall, the wall covered by thick layer of decoration).

Please avoid direct sunlight, rain exposure, snow laying up during installation and operation.

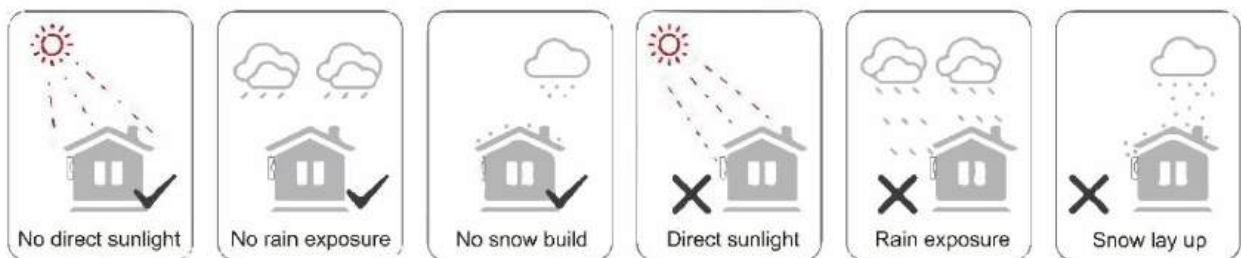

### Space Requirement

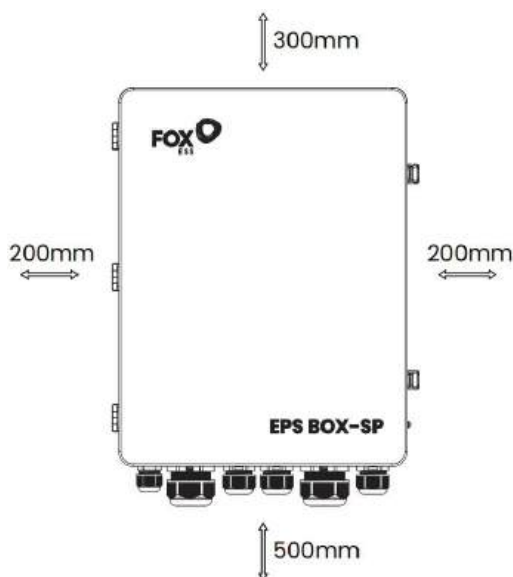

Position	Min Distance
Left	200mm
Right	200mm
Top	300mm
Bottom	500mm

### Tools required for installation:

- Marker pen;
- Electric drill (drill bit set 8mm);
- Crimping pliers;
- Stripping pliers;
- Screwdriver.



### Mounting Steps

#### Step 1: Fix the bracket on the wall

- 1) Choose the place you want to install the EPS BOX-SP.
- 2) Please select solid brick-concrete structure and concrete wall for installation location.  
If other types of wall are selected, the wall must be made of fire-retardant materials and meet the load bearing requirements of the equipment.
- 3) The dimensions (unit: mm) on the back of the machine are as follows:

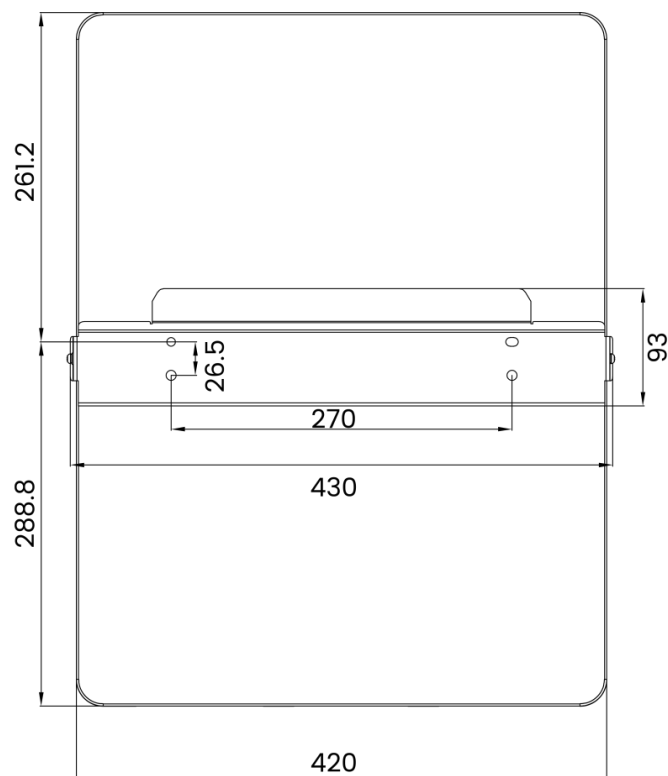

- 4) Before drilling holes, please ensure the distance (unit: mm) between the machine and nearby objects.

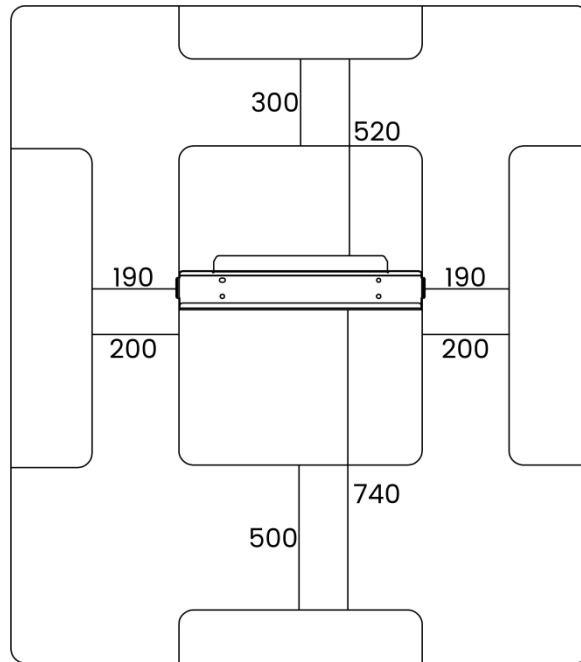

- 5) Place the bracket on the wall and mark the position of the 4 holes from bracket.

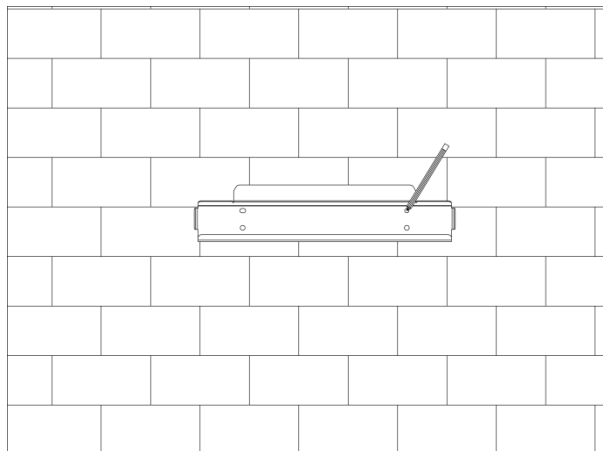

**⚠ DANGER**

Before drilling, please make sure to avoid the water and electricity lines embedded in the wall to avoid danger.

- 6) Drill holes with electric drill, make sure the holes are at least 50mm deep and 8mm wide, and then tighten the expansion tubes.

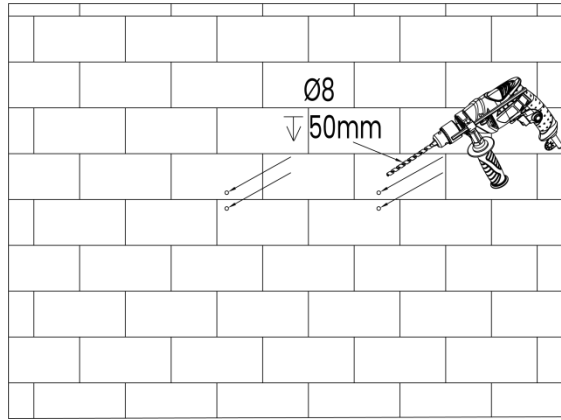

**⚠ CAUTION**

Please pay attention to safety when using the tools. Unsafe use of the drilling tools may cause damage to the body.

- 7) Insert the expansion tubes into the holes and tighten them. Install the bracket with the expansion screws.

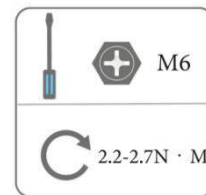
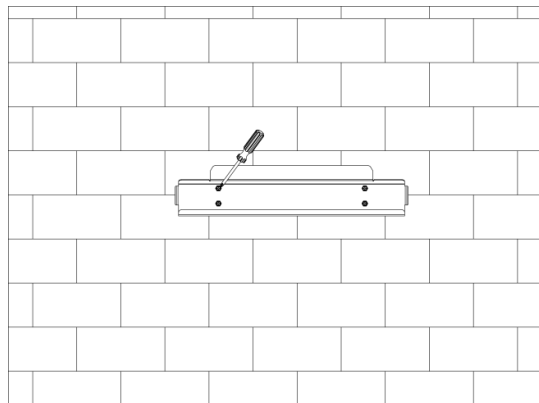

**Step 2: Match the EPS BOX-SP with wall bracket**

Mount the EPS BOX-SP to the bracket and fasten the BOX with two M5 bolts locking on both side.

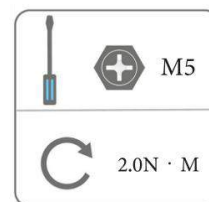
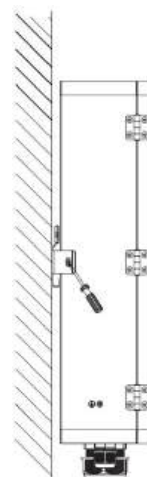
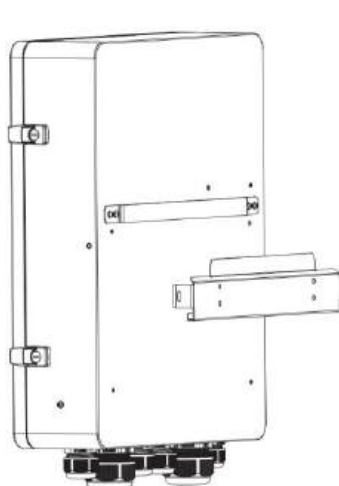

# 3 Electrical Connection

## 3.1 Wiring Connection

- (1) Open the box cover, remove the fixing screws of the insulation board, and then take out the insulation board.

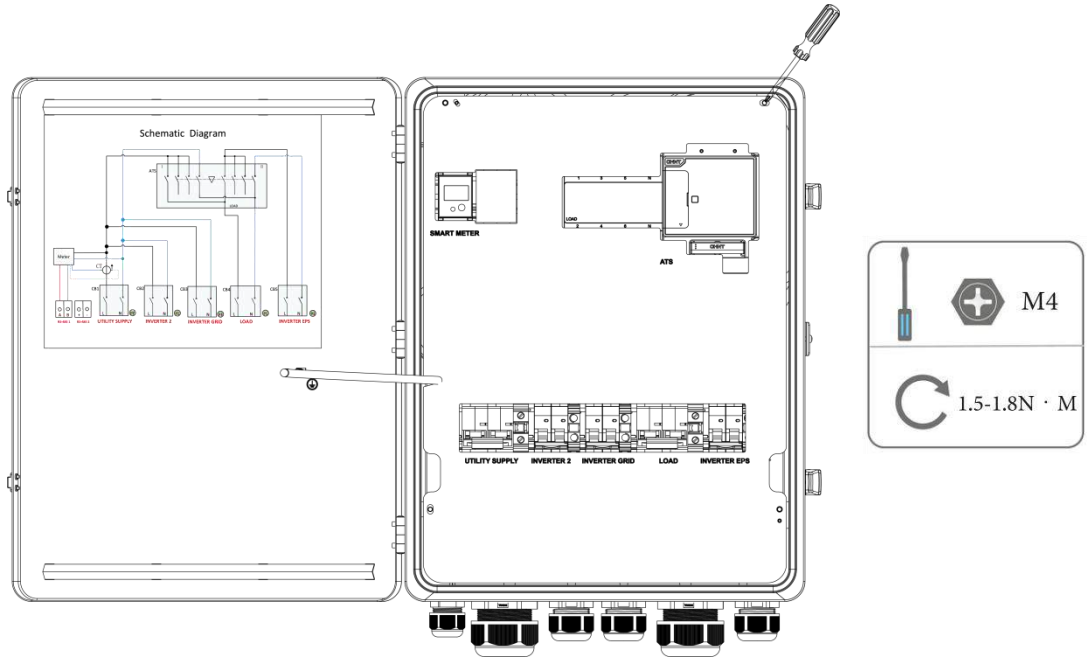

- (2) Pass cable through cable gland and wire according to the marks at the bottom of the box. After wiring all cables, restore the insulation board to its original position and then tighten the box cover.

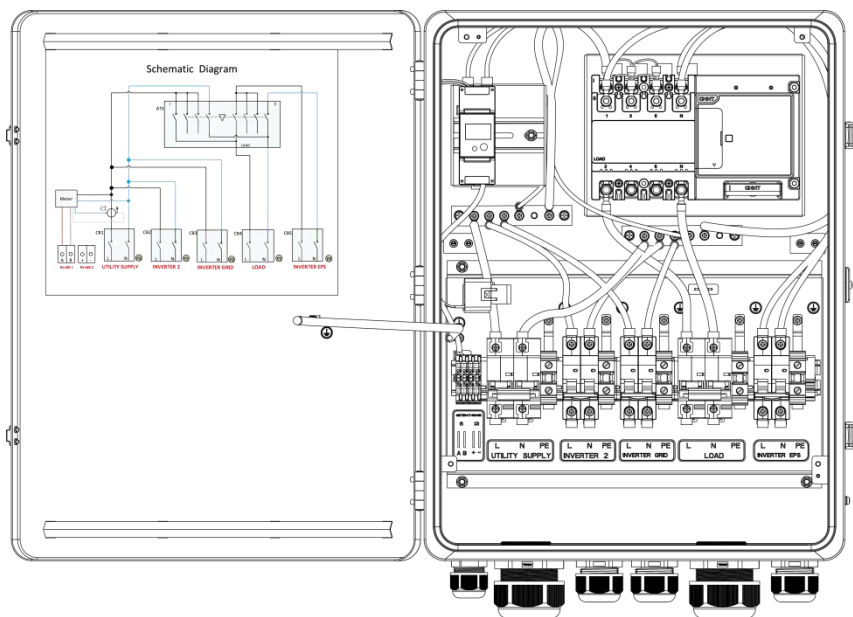

### 3.1.1 INVERTER GRID & INVERTER EPS Wiring Instructions

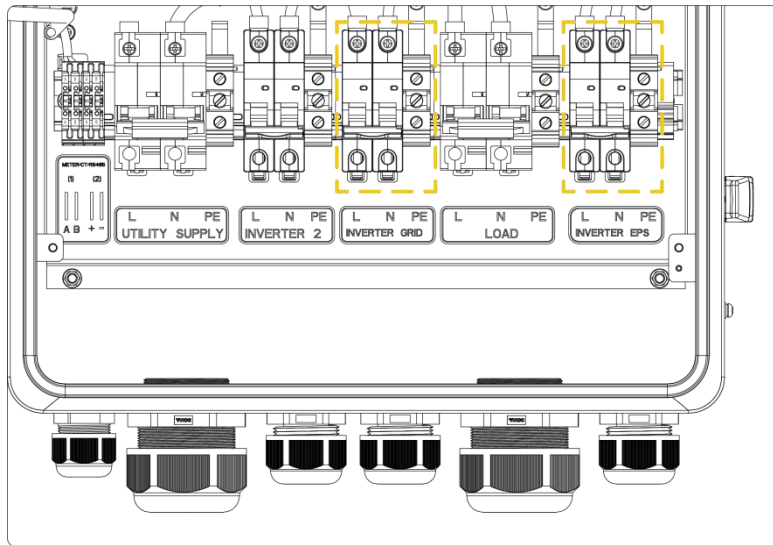

- (1) The wire specification and crimping wire outer diameter is 14-22mm; the wire stripping length is 140mm; the stripping length of the copper-core wire is 14mm (L, N and PE) :

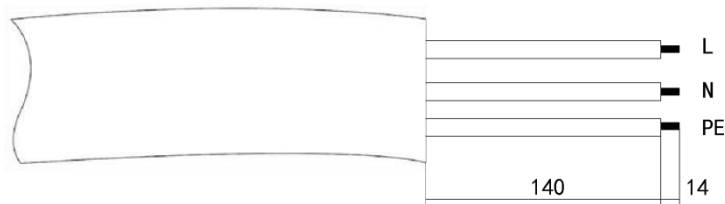

Pass cable through cable gland. Connect L, N and PE to the tubular terminal by crimping (only multi-core soft stranded wires must be crimped to tubular terminal; single core wires, thick stranded hard stranded wires, and tinned fine wire soft stranded wires may not be crimped).

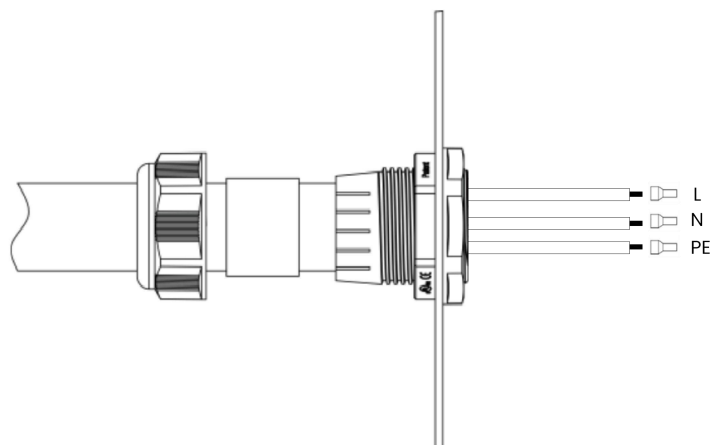

#### NOTE

The EVO series EPS does not have a PE wire, so its EPS can be used with a two-core cable.

- (2) Connect the power lines L, N and PE: Insert them in the circuit breakers and PE connectors in sequence according to the marks on the bottom of the box, and then tighten the screws.

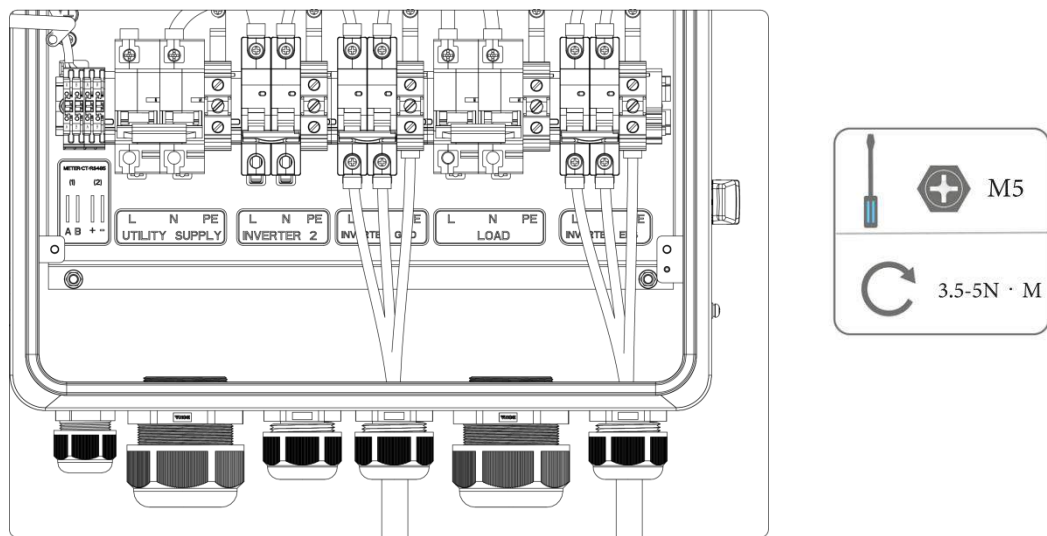

### NOTE

1. It is necessary that PE is connected to a functional ground, even if the grid connection is not active.
2. When parallel-connecting energy storage inverters, considering that the EPS BOX-SP only accepts multi-core flexible stranded cables, all cable paralleling must be completed externally prior to entering the BOX. Ensure the sum of currents entering the BOX does not exceed 63A per phase. Exceeding this limit will trip circuit breakers, causing system failure. Additionally, configure inverters per their user manuals. Prior to installation, confirm the inverters support this functionality.

### 3.1.2 UTILITY SUPPLY & LOAD Wiring Instructions

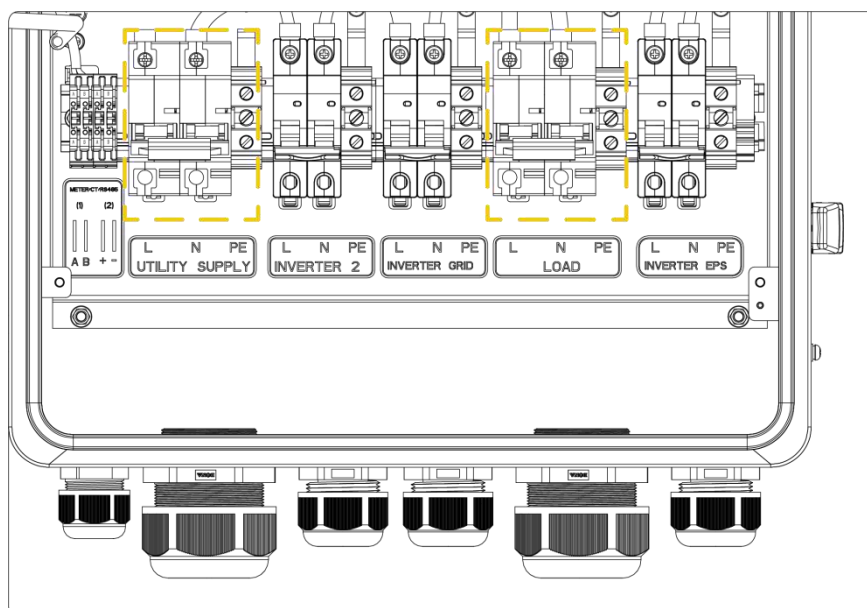

(1) Wire Specifications and Crimping

The wire specification and crimping wire outer diameter is 16-37mm; the wire stripping length is 140mm; the stripping length of the copper-core wire is 18mm (L, N and PE) ;

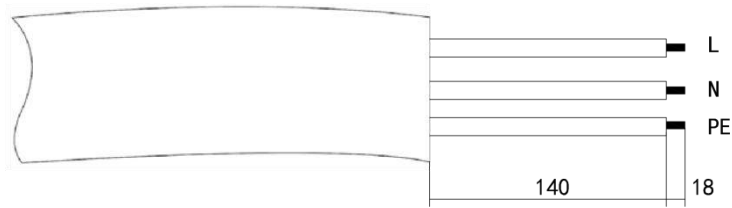

- (2) Pass cable through cable gland. Connect L, N and PE to the tubular terminal by crimping (only multi-core soft stranded wires must be crimped to tubular terminal; single core wires, thick stranded hard stranded wires, and tinned fine wire soft stranded wires may not be crimped).

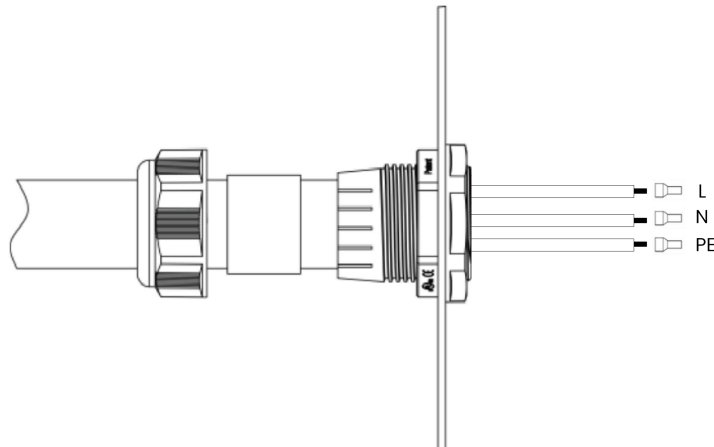

- (3) Connect the power lines L, N and PE: Insert them in the circuit breakers and PE connectors in sequence according to the marks on the bottom of the box, and then tighten the screws.

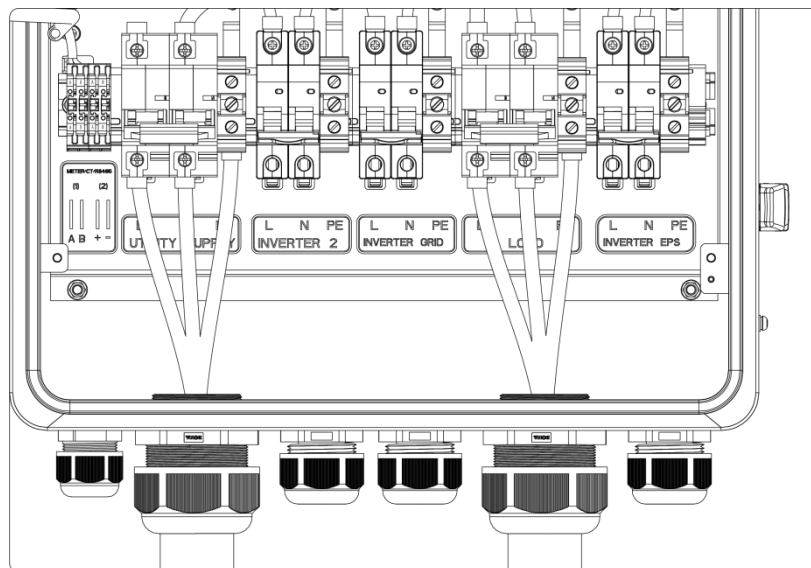

### 3.1.3 RS485 Wiring Instructions

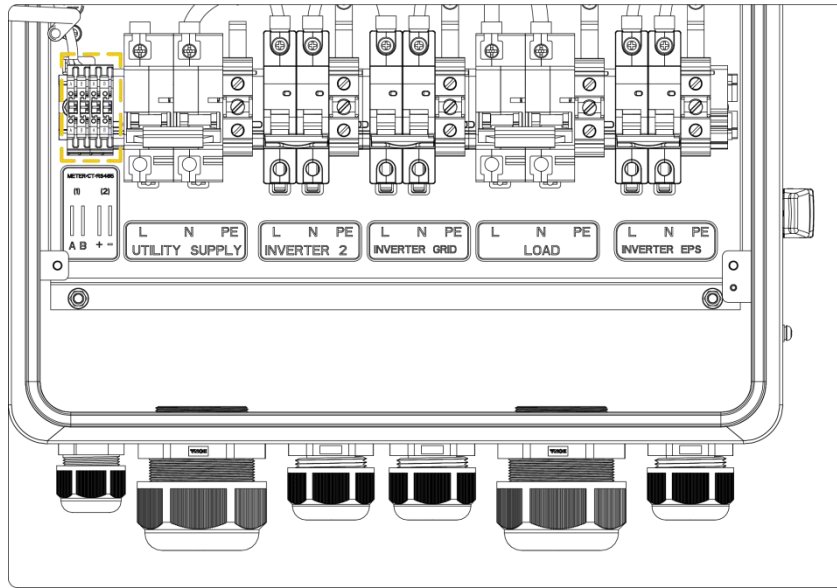

(1) Wire Specifications and Crimping

The wire outer diameter is 3-6.5mm, the stripped length of the wire is 150mm, and the stripped length of the copper core is 10mm;

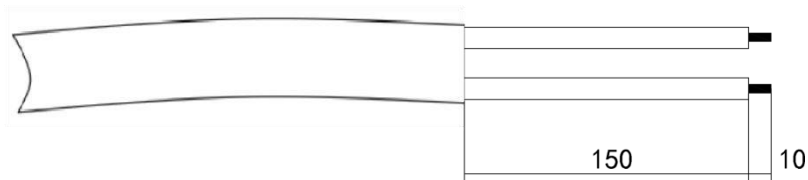

(2) Pass cable through cable gland and crimp the tubular terminal (only multi-core soft stranded wires must be crimped to tubular terminal, single core wires, thick stranded hard stranded wires, and tinned fine wire soft stranded wires may not be crimped).

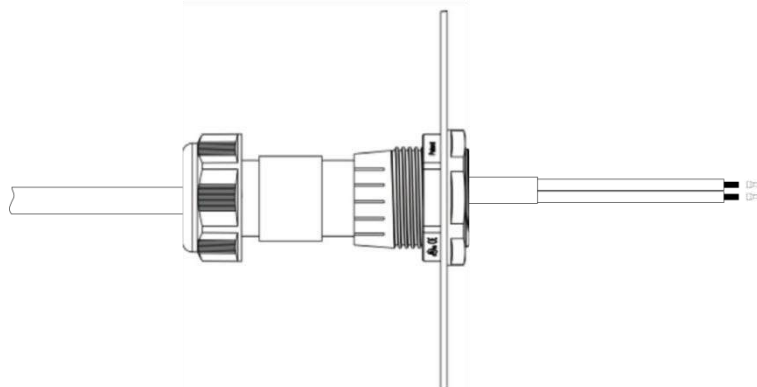

(3) Wiring: Insert into the quick-connect terminal.

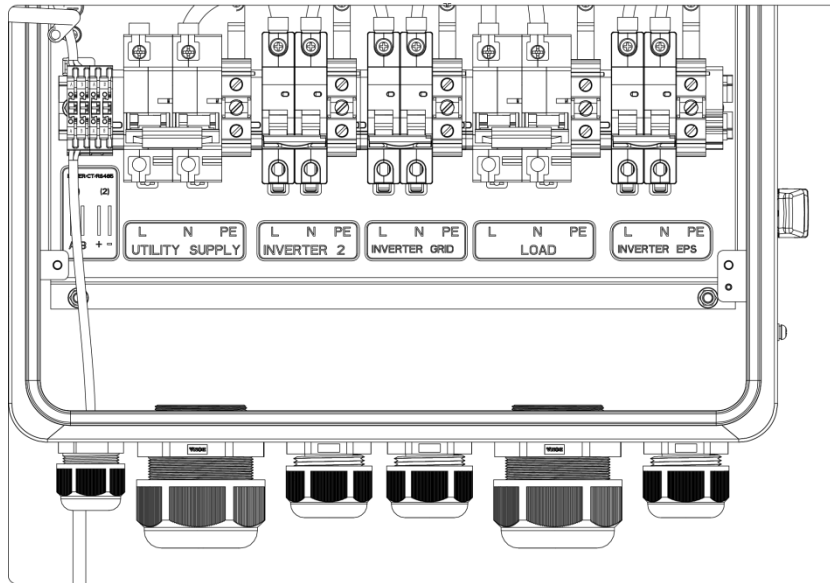

### NOTE

In the case that only one communication cable is required, the extra opening in the leftmost cable glands should be plugged up.

(4) The PIN of the Meter 485 and CT interface of the KH / HI-G2 / EVO series is defined as follows:

For KH and HI-G2 series:

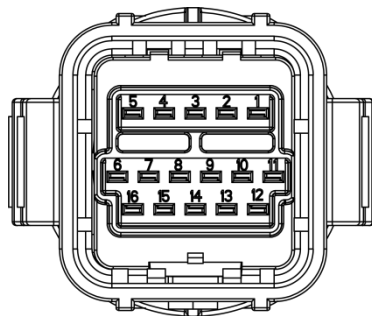

PIN	1	2	3	4	5	6	7	8
Definition	Meter485A	Meter485B	485B	485A	CT2+	CT2-	CT1-	CT1+
PIN	9	10	11	12	13	14	15	16
Definition	/	K1	K2	K3	K4	/	DI	COM

For EVO series:

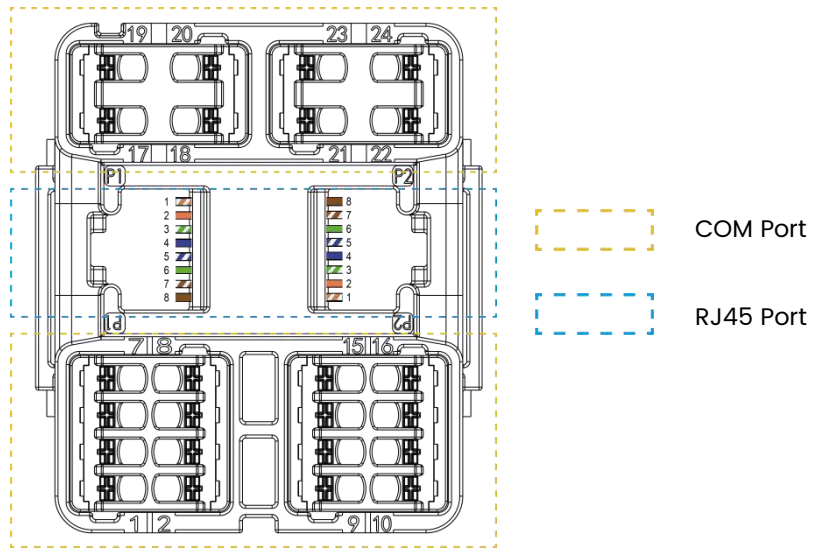

	PIN	PIN Definition		
<b>RJ45 port</b>	1	Paralle_CANH		
	2	Paralle_CANL		
	3	Wifi_485A		
	4	Wifi_485B		
	5	Wifi_485A		
	6	DI		
	7	GND		
	8	12V		
<b>COM port</b>	PIN	PIN Definition	PIN	PIN Definition
	1	DRM1/5	13	CT2+
	2	DRM2/6	14	CT2-
	3	DRM3/7	15	CT1-
	4	DRM4/8	16	CT1+
	5	DRM0	17	K1
	6	RefGen	18	K2
	7	GND	19	K3
	8	Estop	20	K4
	9	Meter_485A	21	Termina_H
	10	Meter_485B	22	Termina_L
	11	485B	23	BMS_CANH
12	485A	24	BMS_CANL	

### 3.1.4 INVERTER 2 Wiring Instructions

Before adding a meter, remove the original meter clips and knock out the pre-existing holes in the insulating bezel.

Check whether the tubular terminals and OT terminals provided in the installation kit are complete to ensure smooth subsequent installation and operation.

Place the retrofit meter against the original meter in the position shown in the illustration and secure the clips in place on the right side, and check for looseness.

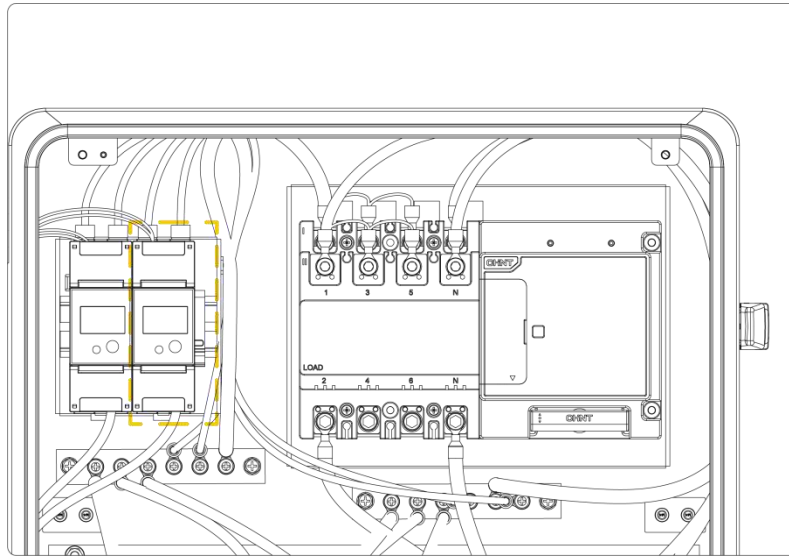

The recommended cross section of the wiring harness from the meter to the copper strip is 6 ~ 10 mm<sup>2</sup>.

The tubular terminal on the meter side is recommended to have a copper core stripped to a length of 12 mm and the OT terminal on the copper row side is recommended to have a copper core stripped to a length of 8 mm.

The total length of the wiring from the left junction above the meter to the copper busbar on the left side of the illustration is 380 mm.

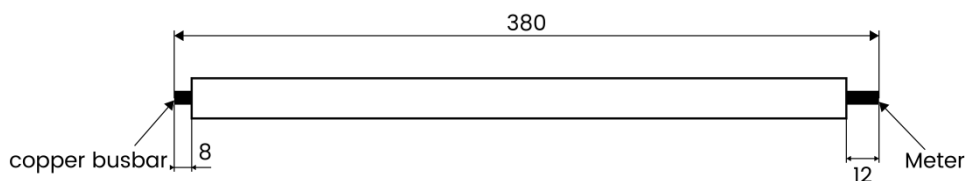

The total length of the wiring from the right junction above the meter to the copper busbar on the right of the illustration is 490mm.

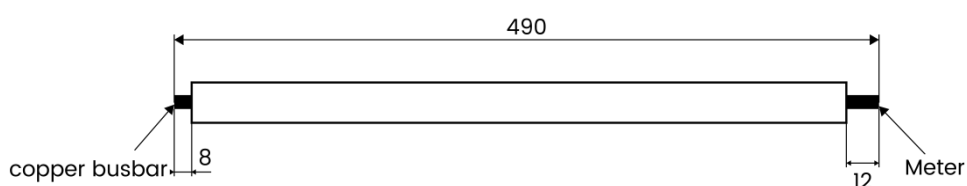

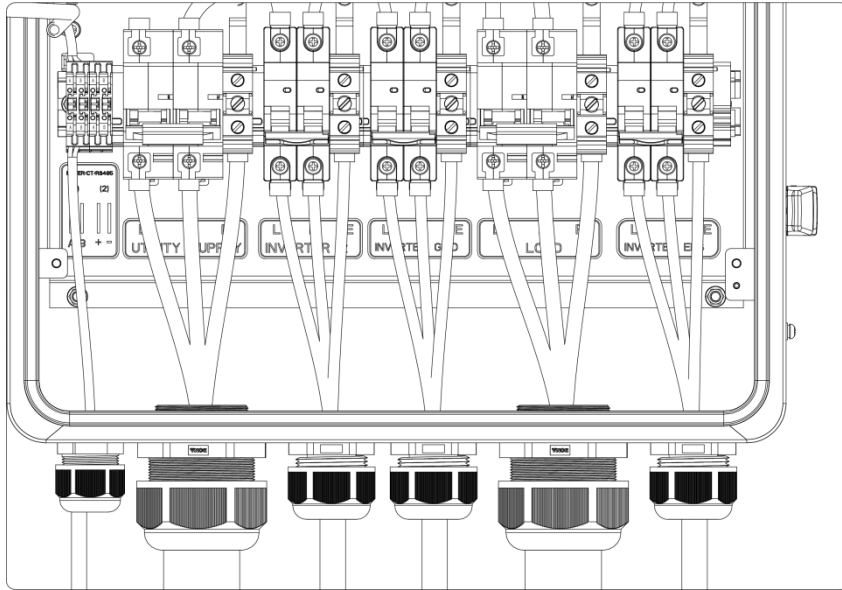

Please see section 3.1.1 for the wiring steps of INVERTER 2.

If Inverter 2 requires an electric meter, connect the meter's RS485 port in parallel with Meter1's RS485 port. Specifically, connect A to A and connect B to B. Additionally, set this meter's communication address to 2.

### 3.1.5 Schematic Diagram After Completing Wiring

With INVERTER 2:

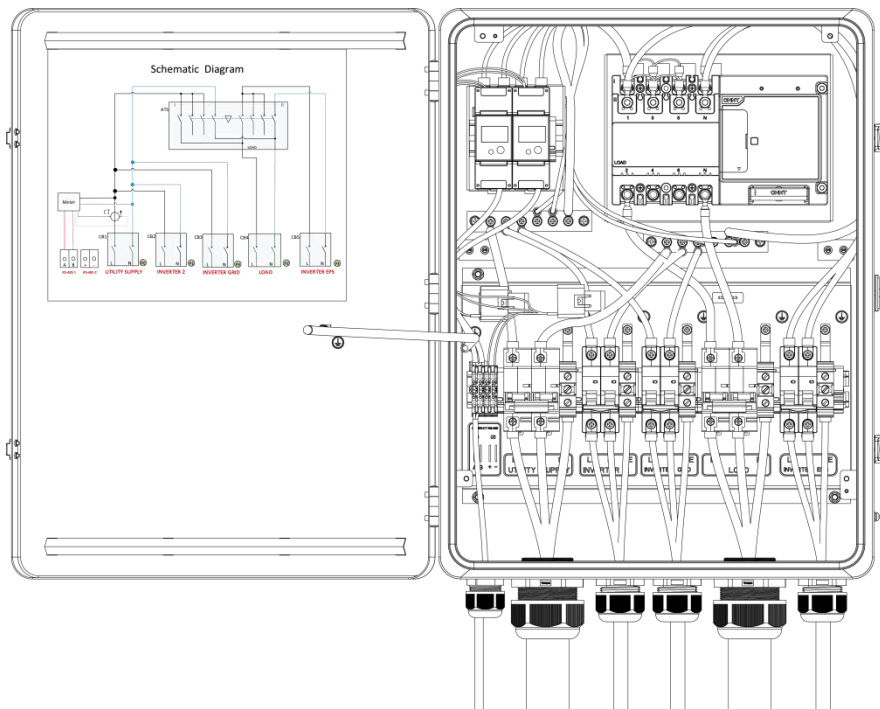

Without INVERTER 2:

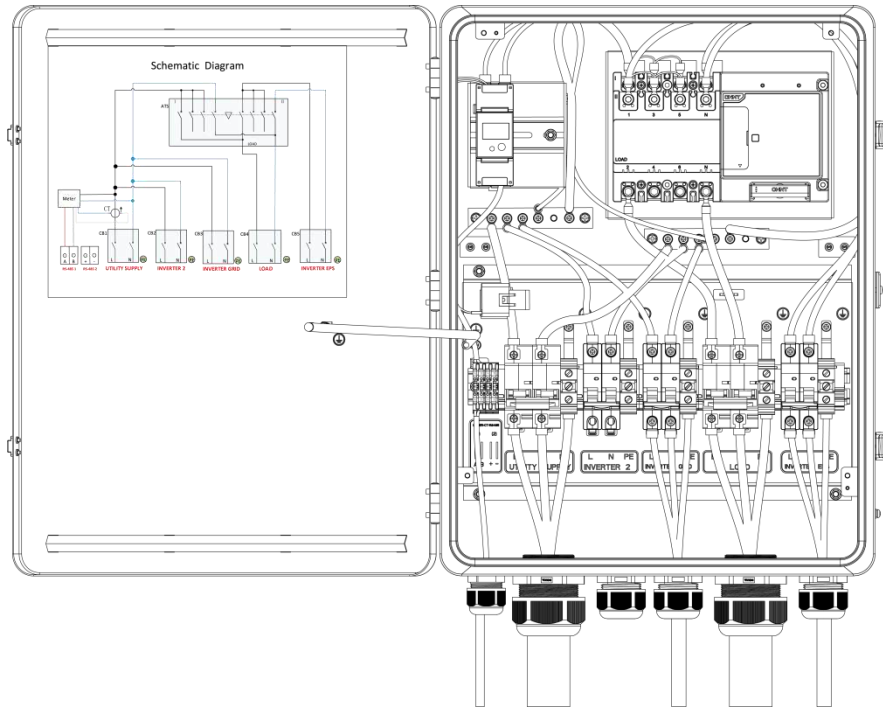

**NOTE**

If the local wiring system is a TN-C-S system, the PE and N wires may be merged. In this case, see the following diagram for the wiring of the grid side. In the figure, INVERTER 2 uses CT sampling. If an electric meter is used, disregard the wiring between METER / CT / RS485(2) and the CT.

With INVERTER 2:

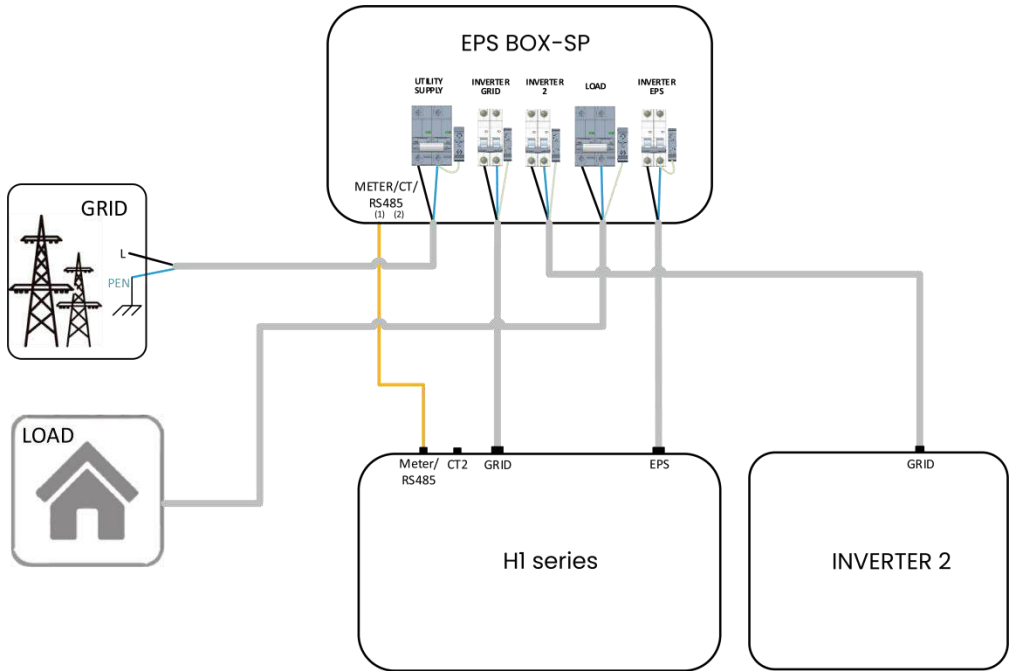

When using a CT, its ratio must match the inverter's preset ratio. For example, inverters of KH/HI-G2/EVO series require a 3000:1 CT ratio. And it must be connected to the CT2 terminal on the inverter. Verify correct CT orientation to prevent abnormal power generation. See the figure below for directional reference.

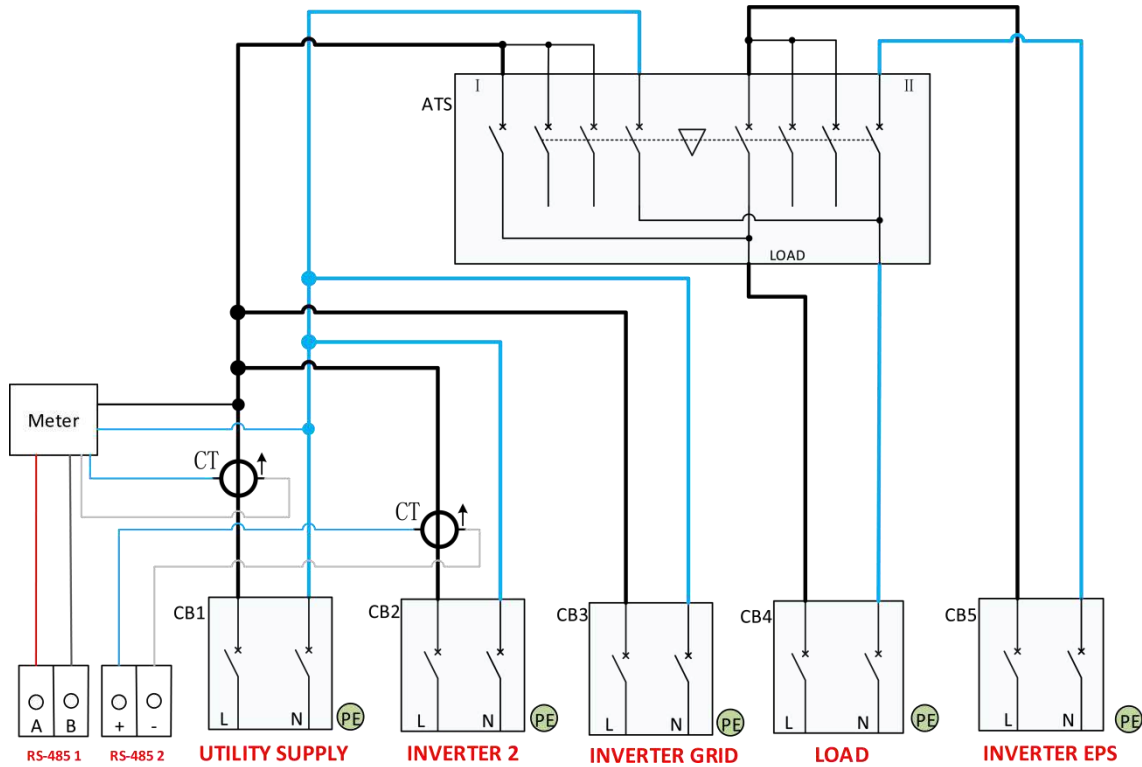

Without INVERTER 2:

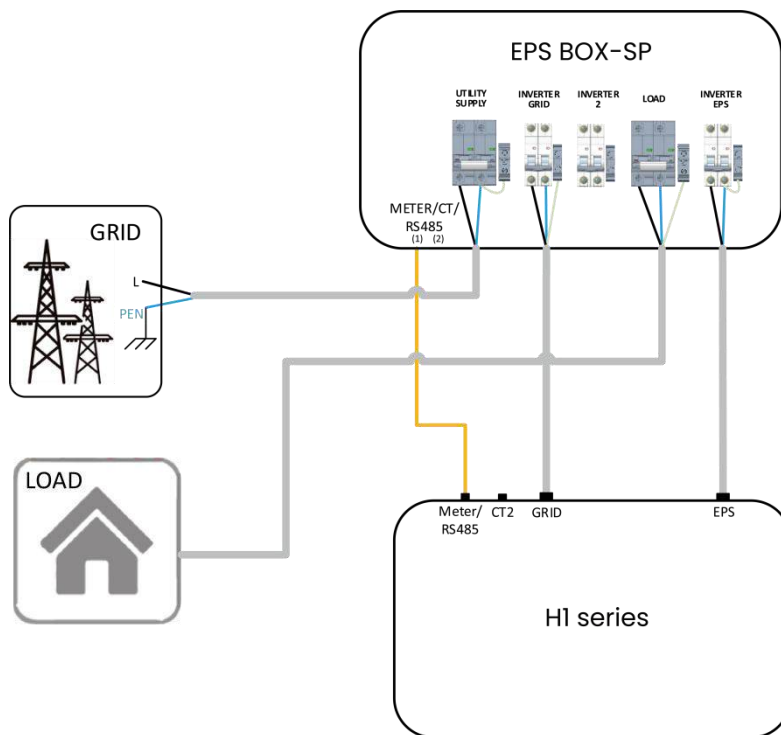

## 3.2 Earth Connection

- (1) Trim 9mm of insulation from the wire end.

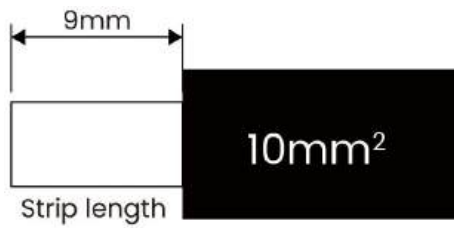

- (2) Insert striped wire into earth terminal and ensure all conductor strands are captured in the earth terminal. Crimp the earth terminal with crimping pliers. Put the earth terminal with striped wire into the corresponding crimping pliers and crimp the contact.

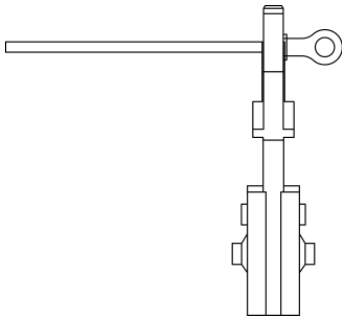

- (3) Use the crimping pliers to press the grounding wire into the ground terminal, screw the ground screw with screwdriver as shown below:

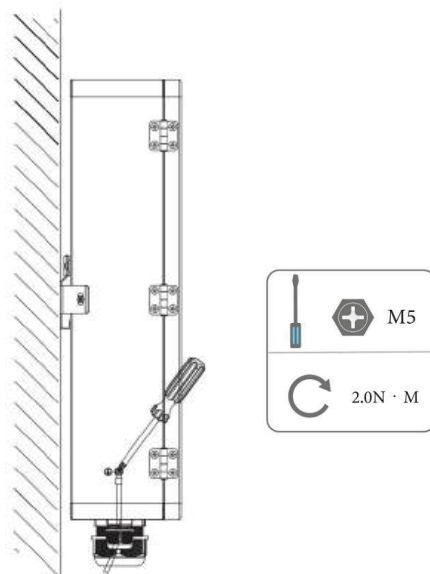

## 4 Check After Installation

### 4.1 Check After Installation

- (1) Check and confirm that the equipment is installed securely and reliably.
- (2) Check if the grounding wire is correctly, firmly and reliably connected.
- (3) Check if the wire is correctly, firmly and reliably connected (confirm if the phase sequence is correct).
- (4) Check if the communication wire is correctly, firmly and reliably connected.

#### NOTE

The default state of the automatic transfer switch equipment is automatic mode. If you need to switch manually, please adjust the double power transfer switch to manual mode.

### 4.2 Maintenance

Before product maintenance and testing, all external power sources must be cut off, and maintenance shall be operated by professional personnel.

Do not modify the product during maintenance. Our Company is not responsible for any problems caused by unauthorized modification.

## 5 Technical Data

EPS BOX-SP specification	
Model	EPS BOX-SP
<b>UTILITY SUPPLY</b>	
Rated voltage	220/230/240VAC, L/N/PE
Rated frequency	50/60Hz
Max. input current	100A
<b>INVERTER GRID</b>	
Rated voltage	220/230/240VAC, L/N/PE
Rated frequency	50/60Hz
Max. input current	63A
<b>INVERTER EPS</b>	
Rated voltage	220/230/240VAC, L/N/PE
Rated frequency	50/60Hz
Max. input current	63A
<b>Load</b>	
Rated voltage	220/230/240VAC, L/N/PE
Rated frequency	50/60Hz
Max. output current	100A
<b>INVERTER 2</b>	
Rated voltage	220/230/240VAC, L/N/PE
Rated frequency	50/60Hz
Max. input current	63A
<b>Communication interface</b>	
RS-485 (Meter)	
<b>General Data</b>	
Cooling concept	Natural
Installation	Wall-mounted
Operating temperature range	-25 ... +60°C
Dimensions (W*H*D)(mm)	
Dimensions of packing (W*H*D)(mm)	
Net Weight (Kg)	
Gross Weight (Kg)	
Ingress protection	IP65

**⚠ CAUTION**

In the off-grid mode, derating is required when the operating temperature exceeds 45°C. Please refer to the table below for specific derating.

For derating use, please refer to the following table:

Ambient Temperature (°C)	45	50	55	60
Max. Current (A)				
Load Current (A)	60	58	57	55

## Appendix: ATS Manual Mode Operation Schematic

Toggle the slide cover to the left until the arrow indicates that it is in the manual position, and pull out the handle and insert it into the conversion hole for conversion operation.

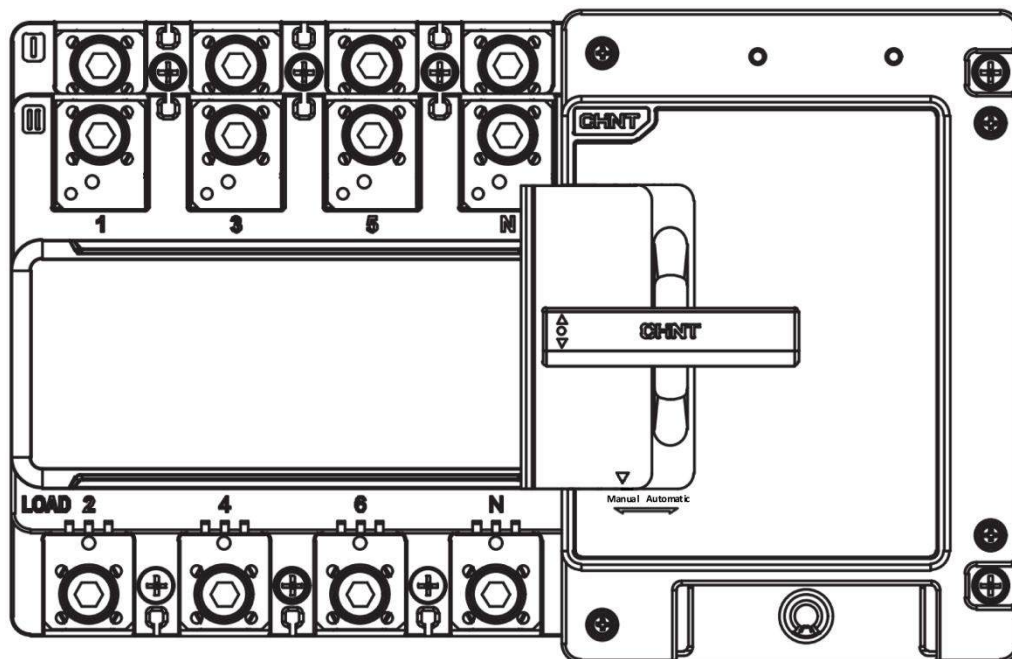
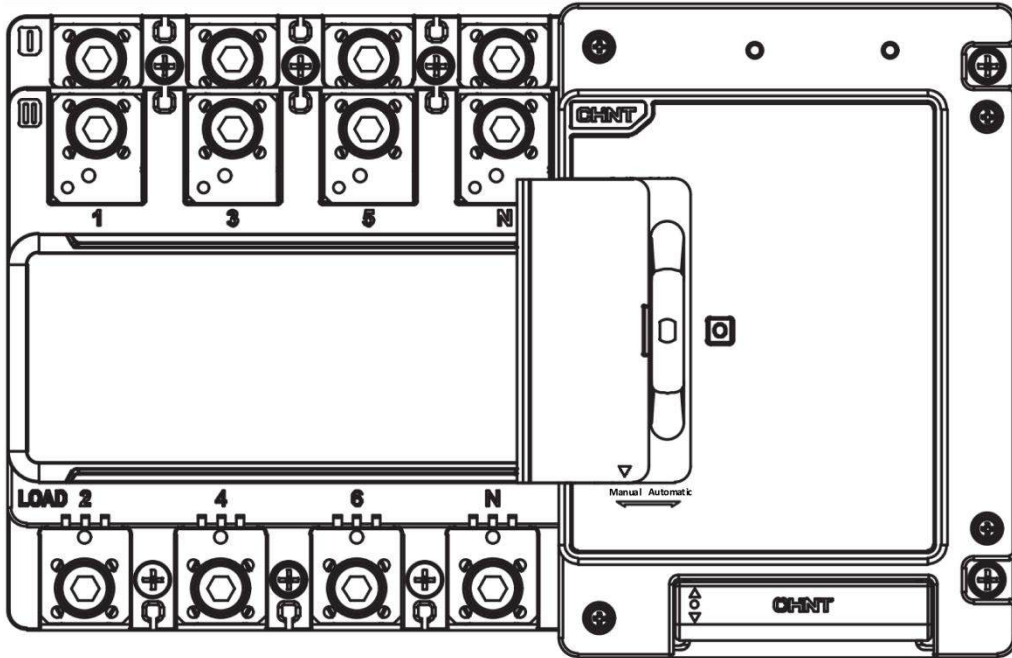

- Double Open Position -

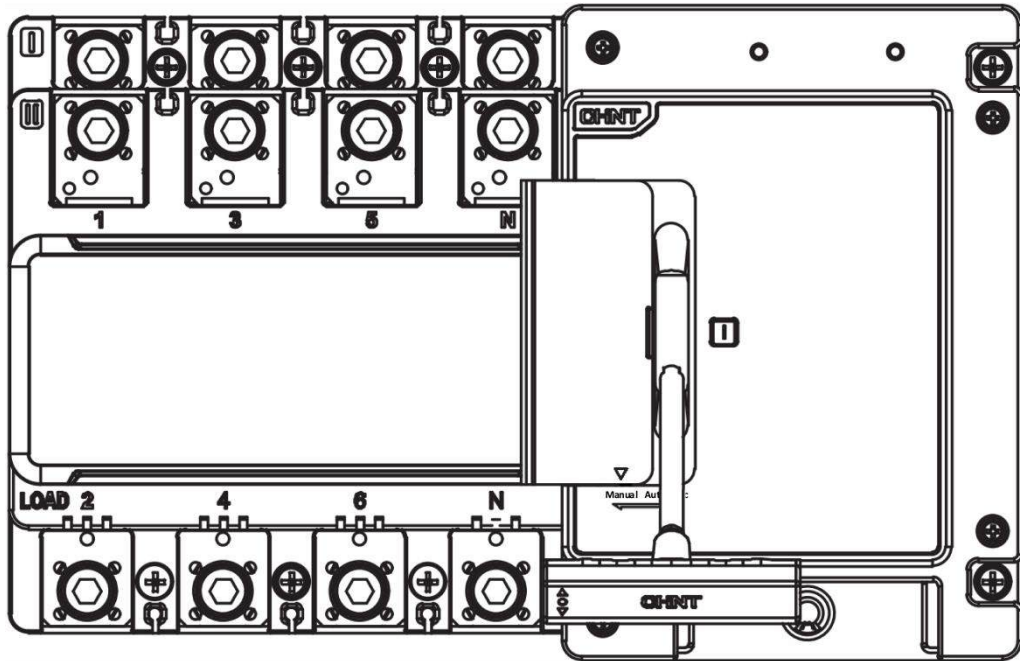

- Power Supply 1 Closed -

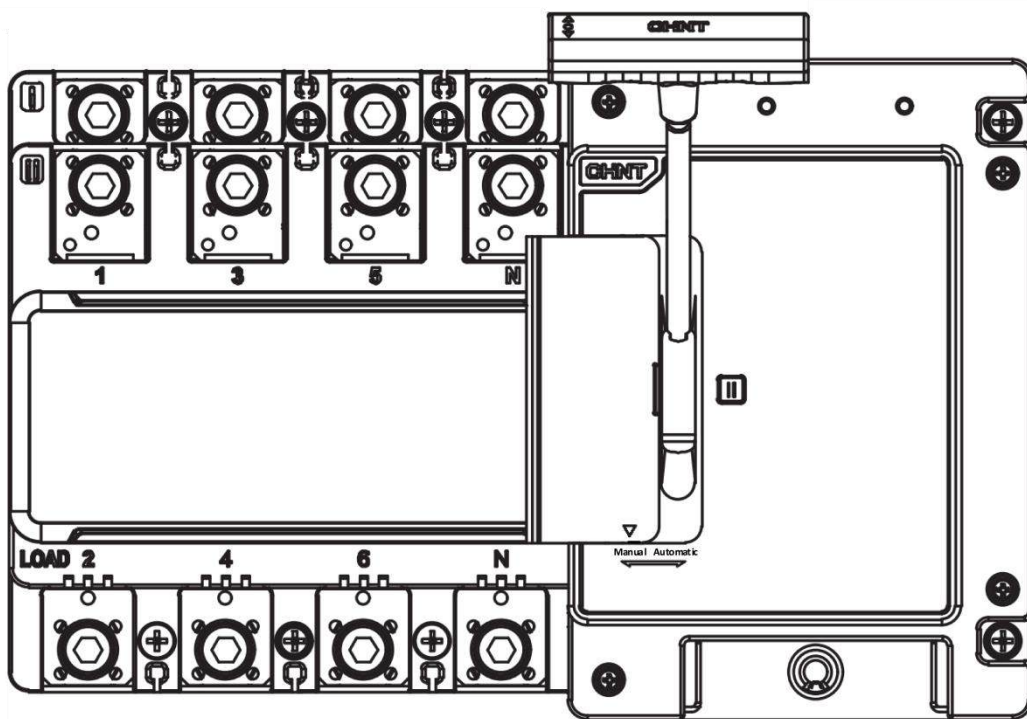

- Power Supply 2 Closed -

**NOTE**

The position of the arrow is the current working mode. In manual mode, you must keep the arrow pointing to "manual." If you want to return to automatic mode, please push the arrow to "automatic".

The copyright of this manual belongs to FOXESS CO., LTD. Any corporation or individual should not plagiarize, partially or fully copy (including software, etc.), and no reproduction or distribution of it in any form or by any means is permitted. All rights reserved.

**FOXESS CO., LTD.**

Add: No.939, Jinhai Third Road, New Airport Industry Area, Longwan District,

Wenzhou, Zhejiang, China

Tel: 0510- 68092998

Web: [WWW.FOX-ESS.COM](http://WWW.FOX-ESS.COM)