

# Alteas ONE+ NET



The Alteas ONE+ NET has an ultra-premium feel with a beautiful black finish. It is compatible with 20% Hydrogen blends and comes ready for connection to the Ariston NET app.

- / XtraTech™ stainless steel heat exchanger
- / 12 year warranty
- / Built-in Wi-Fi & digital timer programming
- / Up to 94% seasonal efficiency and A+ energy rating thanks to supplied controls
- / Cube RF and receiver included in the box
- / Boiler Plus ready out of the box
- / Ariston NET ready out of the box for smartphone control
- / Low NOx ratings (from 24mg/kWh)
- / Premium Ultrasafe glass panel
- / Auto calibration on fuel type from gas to LPG
- / Market leading efficient unit thanks to its enhanced ignition and flow control systems+
- / 1:10 modulation ratio
- / Advanced Diagnostic and Data Science
- / Quiet operation at 49dB
- / High domestic hot water flow rates
- / AUTO, COMFORT, CARE and TIME PROGRAMMING functions
- / Quick and easy to install, thanks to its single sealed unit and front panel touch bottoms

ENERGY RATING



**XtraTech™**  
stainless-steel heat exchanger

PERFORMANCE  
CERTIFIED BY  
TÜV RHEINLAND  
GROUP



www.tuv.com  
ID 0000056520



ARISTON NET



ENERGY EFFICIENT



VOICE CONTROL



SPACE SAVING



COMFORT FUNCTION



SMART MENU



ITALIAN DESIGN



SYSTEM MANAGEMENT



AUTO FUNCTION



EASY INSTALLATION



EASY MAINTENANCE



**CUBE RF**  
ROOM SENSOR  
included

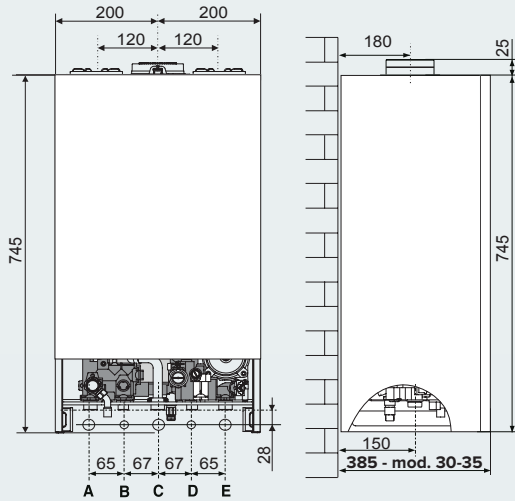

**KEY**

- A \ Central heating flow
- B \ Domestic hot water outlet
- C \ Gas inlet
- D \ Domestic hot water inlet
- E \ Central heating return

**Coaxial flue**

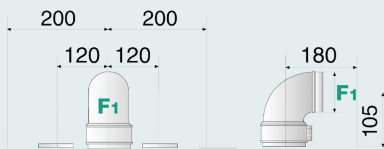

**Maximum flue length:**

- Ø60/100: up to 7m (30) - 6m (35)
- Ø80/125: up to 20m (30) - 24m (35)

Twin flue configurations also possible

Coaxial manifold exhaust / intake

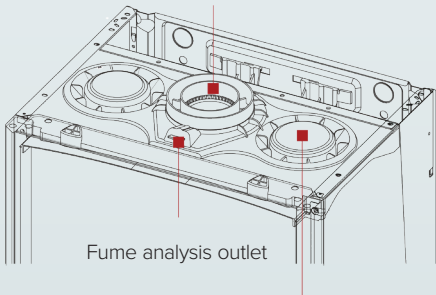

Fume analysis outlet

Air intake manifold for split exhaust systems

**Hydraulic scheme**

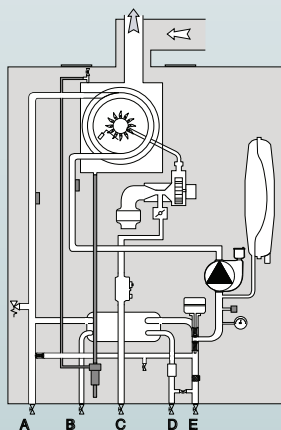

Please see installation manual for full details

**Efficiency**

Energy rating - heating/DHW	Rating	A/A
Energy rating data - seasonal space heating efficiency	%	94
Energy rating data - noise level	dB	49
Energy rating data - tapping profile	-	XXL
SEDBUK rating	Band	A
SAP efficiency 2005	%	90.3
SAP efficiency 2009/2012	%	89.3

**Power & Performance**

DHW flow rate ΔT @ 35°C	l/min	14.1
Heat output max (CH)	kW	31
Heat output max (DHW)	kW	34.5
Min/Max heating temperature (high temp. range)	°C	35/82
Min/Max heating temperature (low temp. range)	°C	20/45
DHW temperature min/max	°C	36/60

**Characteristics**

Minimum ambient temperature	°C	+5
DHW minimum flow rate	l/min	2
DHW pressure - min/max	bar	0.2/7.0
Built-in expansion vessel capacity	l	8
Servicing clearances - top/front/bottom	mm	350/450/300
Servicing clearances - left/right	mm	10/10
Weight	kg	36
NOx	mg/kWh	24
Dimensions HH x WW x DD	mm	745 x 400 x 385

**Electrical Data**

Electrical supply	V/Hz	230V - 50 Hz
Protection grade of electrical system	IP	X5D

**Product Codes**

3302395

**Home gets smarter, life gets simpler**

**Enjoy Ariston NET connectivity**

**Comfort at your fingertips with the Ariston NET app**

